

Bulletin OIML n° 116

Septembre 1989

ISSN 0473-2812

BULLETIN

DE

L'ORGANISATION

INTERNATIONALE

DE MÉTROLOGIE LÉGALE

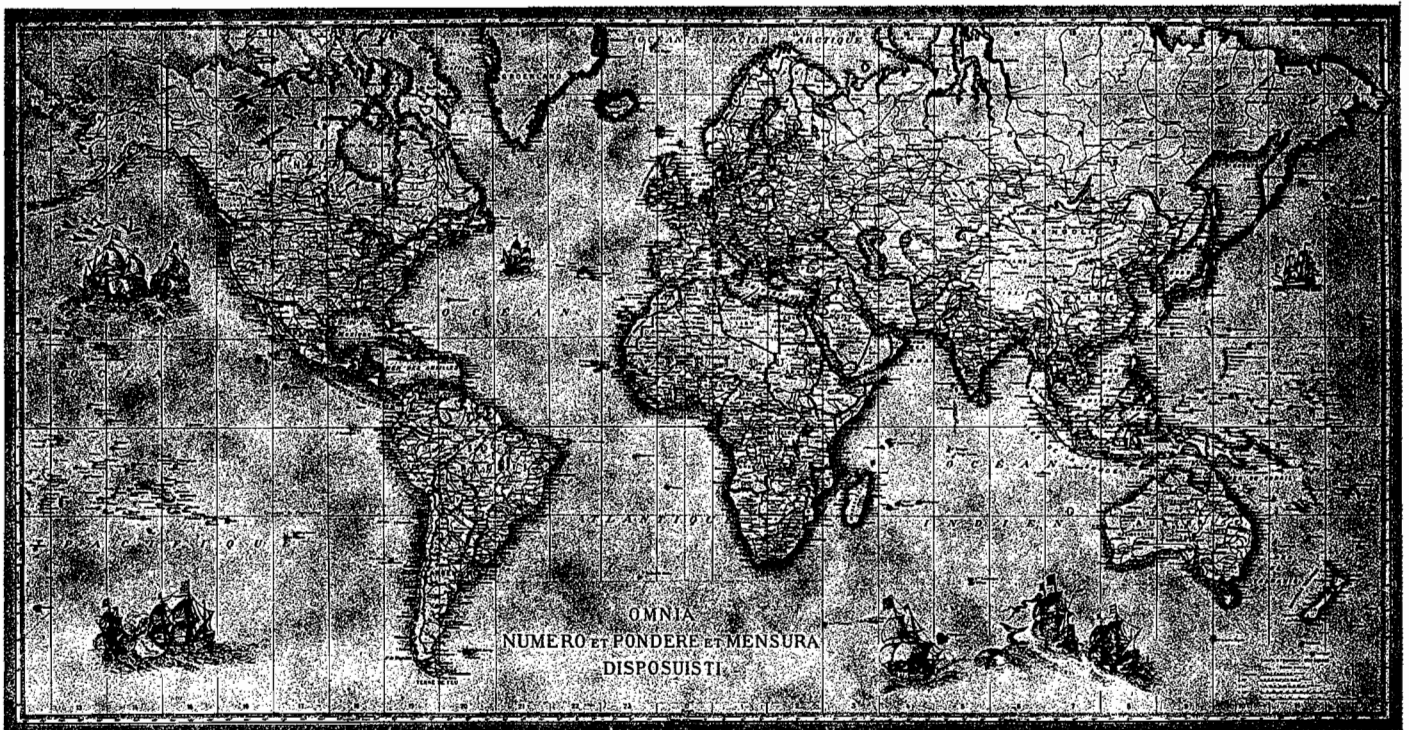

BUREAU INTERNATIONAL DE METROLOGIE LEGALE
11, Rue Turgot — 75009 PARIS — France

BULLETIN
de
L'ORGANISATION INTERNATIONALE de MÉTROLOGIE LÉGALE

SOMMAIRE

	Pages
REPUBLIQUE FEDERALE D'ALLEMAGNE — Gravimetric measuring device for liquids at rest in storage tanks by M. KOCHSIEK and H. SCHNEIDER	3
New weighing center at the Office of Weights and Measures for Legal Metrology in West-Berlin by D. BAUMGARTEN	11
FRANCE — Calibration of tanks by internal optical method by P. CANAVAGGIO and P. DEMANY	21
PAYS-BAS — L'Institut Néerlandais de Mesures, NMI par G.J. FABER	30
— The Netherlands Measurement Institute (NMI) by G.J. FABER	33
TCHECOSLOVAQUIE — Comparison of geometric calibration methods for storage measuring tanks by I. CHREN	35
In Memoriam — Jerzy JASNORZEWSKI	43
 INFORMATIONS	
Français	44
Littérature	45
English	47
Literature	48
Réunions OIML	50
 DOCUMENTATION	
Publications : Liste complète à jour	51
Etats membres de l'Organisation Internationale de Métrologie Légale	58
Membres actuels du Comité International de Métrologie Légale	59
Adresses des Services des Membres Correspondants	64

Abonnement pour 1990 : Europe : 175 F-français
Autres pays : 230 F-français
Chèques postaux : Paris 8 046-24 X
Banque de France : B.P. 140-01 - 75049 Paris Cedex 01
Comptes Courants, Banques Etrangères, Cpte n° 5051-7

BUREAU INTERNATIONAL DE METROLOGIE LEGALE
11, Rue Turgot — 75009 Paris — France
Tél. 33 (1) 48 78 12 82 Le Directeur : Mr B. ATHANÉ
et 42 85 27 11 Télécopie : 33 (1) 42 82 17 27
Télex : SASVP 215463F ATTN OIML

GRAVIMETRIC MEASURING DEVICE for LIQUIDS at REST in STORAGE TANKS

by M. KOCHSIEK * and H. SCHNEIDER **

SUMMARY — This article describes a method for measuring the quantities of liquids at rest by which the mass is determined by measuring the hydrostatic pressure at the bottom of a storage tank using a piston connected to a weighing device.

The authors also discuss the possible applications of this tank weighing system and its merits compared to other mass measuring methods. The relative uncertainty is of the order of ± 0.05 % within the range of 3 to 100 % of the tank capacity. The device is subjected to legal control in some countries.

RESUME — Cet article décrit une méthode de mesure des quantités de liquide au repos par laquelle la masse est déterminée en mesurant la pression hydrostatique au fond de la citerne au moyen d'un piston relié à un dispositif de pesage.

Les auteurs traitent également les applications possibles de ce procédé et ses mérites par rapport à d'autres méthodes de mesure de la masse. L'incertitude relative est de l'ordre de ± 0.05 % dans l'étendue de 3 à 100 % de la capacité de la citerne. Le dispositif est soumis au contrôle légal dans certains pays.

1 — Introduction

The quantity of a liquid at rest is either indicated as a volume V or as a mass m . Mass indications are to be preferred because, in contrast to volume, mass is independent of temperature and density. In order to transfer volume data into mass data according to the formula $m = \rho \cdot V$, the density ρ of the liquid must be known.

It is generally more important to know exactly the mass of a liquid than its volume. Thus, for example, the chemical energy of a fuel is proportional to its mass and not to its volume (the determination of which is easier). The mass of small quantities of liquid is frequently determined by weighing and great quantities by volume and density measuring. Reliable measuring methods have been developed for the determination of the volume of storage tanks [1] [2] [3]; the same applies to density measurement [4].

Mass determination via volume and density measuring is very time-consuming on the one hand, as the taking of samples is necessary, on the other hand the density values are not always representative due to density variations within the medium. The uncertainties for volume and mass determinations, in large tanks are about 0.1 % or 0.5 %, respectively. A more accurate gravimetric determination by means of tank weighing (≤ 0.1 %), e.g. by use of load cells, is only possible with relatively small tanks.

An exact and simple mass determination of liquids at rest is however possible by the measuring principle described below which is based on the measurement of the hydrostatic pressure at the tank bottom by means of a weighing device (differential pressure weighing device).

* Physikalisch-Technische Bundesanstalt, Braunschweig, FRG.

** Fa Pfister, Augsburg, FRG.

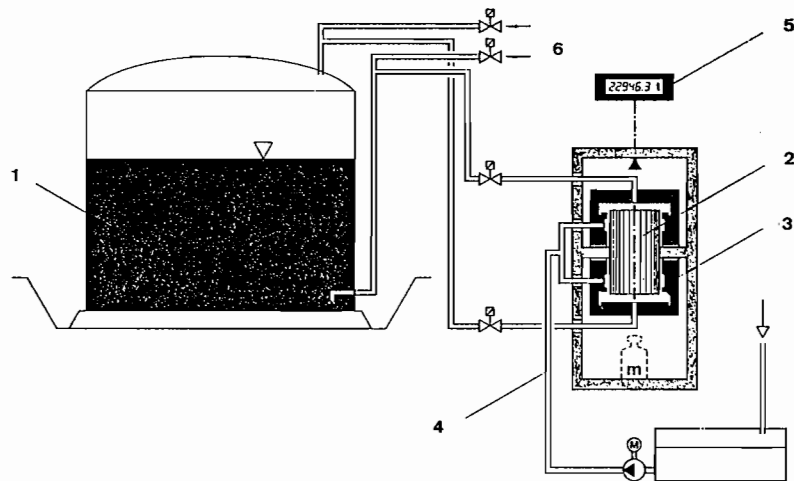

Fig. 1 — Operational principle of tank weighing assembly

- 1 storage tank
- 2 measuring piston
- 3 cylinder
- 4 hydraulic liquid supply
- 5 electro-mechanical weighing device with indication
- 6 bubble system

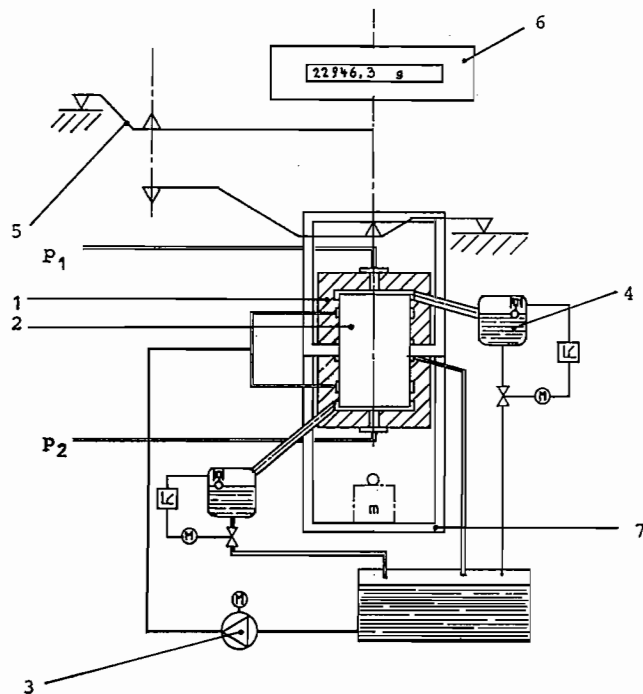

Fig. 2 — Schematic representation of the tank weighing device

- 1 hydrostatic cylinder
- 2 hydrostatic piston
- 3 hydraulic supply pump
- 4 oil return flow controller (electromechanical or mechanical)
- 5 lever system
- 6 electromechanical precision weighing device
- 7 mass control frame

2 — The measuring principle of the tank weighing device

The mass determination of the liquid stored in the tank (Fig. 1) is performed by measuring the hydrostatic pressure by means of a piston and taking into account the ratio between the cross-section of the tank and that of the piston [5]. With open tank the reference pressure is the atmospheric pressure, with closed tank the reference pressure is measured below the fixed roof or below the floating roof or the floating cap, respectively.

The form of the tank as well as the deformation of the tank depending on the liquid level (elastic deformation) are determined once and the resulting "tank table" is stored in a microprocessor unit. The differential pressure is directly proportional to the liquid level in the tank and can be measured with an uncertainty of 0.005 % or less.

The hydrostatic pressure and the gas pressure above the liquid level are applied to the piston so as to produce a force proportional to the pressure difference $\Delta p = p_2 - p_1$. This force is transmitted by a system of levers to an electronic weighing instrument connected to the data processing electronics.

As is shown in Fig. 2 the piston is rendered frictionless by an independent hydraulic device which generates a hydraulic pressure between the measuring piston and the cylinder controlled by a pressure switch. Thus frictionless separation and simultaneous sealing of the measuring piston and the cylinder are performed. The hydraulic liquid leaving at the piston sides is kept at a constant level by means of control units in the connected overflow vessels.

The mechanical power transmission as well as the electronic evaluation can be tested and calibrated by application of masses using a testing device incorporated in the instrument. By means of bubbling gas in a pipe between the tank and the tank weighing device the hydraulic pressure can be transmitted up to a distance of 1 000 m.

3 — Determination of the stored quantities

3.1 Determination of the hydrostatic pressure from the indication of the weighing instrument

$$\Delta p = G \cdot F$$

where

Δp = hydrostatic pressure (Pa)

G = indication of the weighing device (kg)

F = calibration factor (Pa/kg) obtained by empiric determination using a pressure standard.

3.2 Pressure correction

The measured pressure Δp is subject to a small correction due to the change in the air column pressure as a function of the liquid level. The corrected pressure is

$$\Delta p_k = \Delta p + f_p \cdot h$$

where f_p is the change of the air pressure per metre change in the level h .

$f_p = 0.000\ 125 \times$ actual pressure, i.e. 12.66 Pa/m at the standard pressure of 101 325 Pa (1 013 mbar).

3.3 Calculation of the liquid level

$$h = \frac{\Delta p_k}{\rho_l \cdot g} = \frac{\Delta p + f_p \cdot h}{\rho_l \cdot g}$$

thus

$$h = \frac{\Delta_p}{\rho_t \cdot g - f_p}$$

where ρ_t is the density of the liquid at the temperature t and g the local acceleration due to gravity.

3.4 Determination of the volume

The volume of the tank at the reference temperature of 20 °C as a function of the liquid level can be obtained from the tank table. The verification of storage tanks is in fact usually based on the reference temperature of 20 °C whereas the reference temperature for many liquids [6] is 15 °C. Linear interpolation can however be done between two samples.

The tank table will be either established by the verification office or it can be obtained by means of a quantity determination method which is a comparison of defined stored quantities to the indication of the tank weighing device.

$$V = f(h)$$

where

V = volume of the stored liquid (m³)

h = liquid level (m).

The true volume at the measured temperature of the tank can be found from the formula

$$V_k = V [1 + 2 \alpha(t - 20)]$$

where

V_k = corrected volume of the stored liquid (m³)

V = volume of the stored liquid according to the tank table (m³)

α = linear thermal expansion coefficient of the material of the tank wall (°C⁻¹)

t = measured temperature (°C).

3.5 Determination of the mass

The mass of the liquid is obtained from

$$m = V_k \cdot \rho_t$$

where

m = stored quantity (kg)

V_k = corrected volume of the stored liquid (m³)

ρ_t = density of the liquid at the temperature of the measurement (kg/m³).

However, as V_k is a function of h which is determined through the measurement of the differential pressure (see 3.3) and thus inversely proportional to ρ_t (if f_p is neglected), the computed mass will be practically independent of the density.

The effect of the local value of the acceleration due to gravity g will also be balanced out due to the fact that calibration of the device is made by weights which are subjected to practically the same value of g .

4 — Technical description and application possibilities

The tank weighing device consisting of measuring piston system with hydraulic part, bubbling gas supply unit, control, weighing instrument and measuring value processor is of compact design, see Fig. 3.

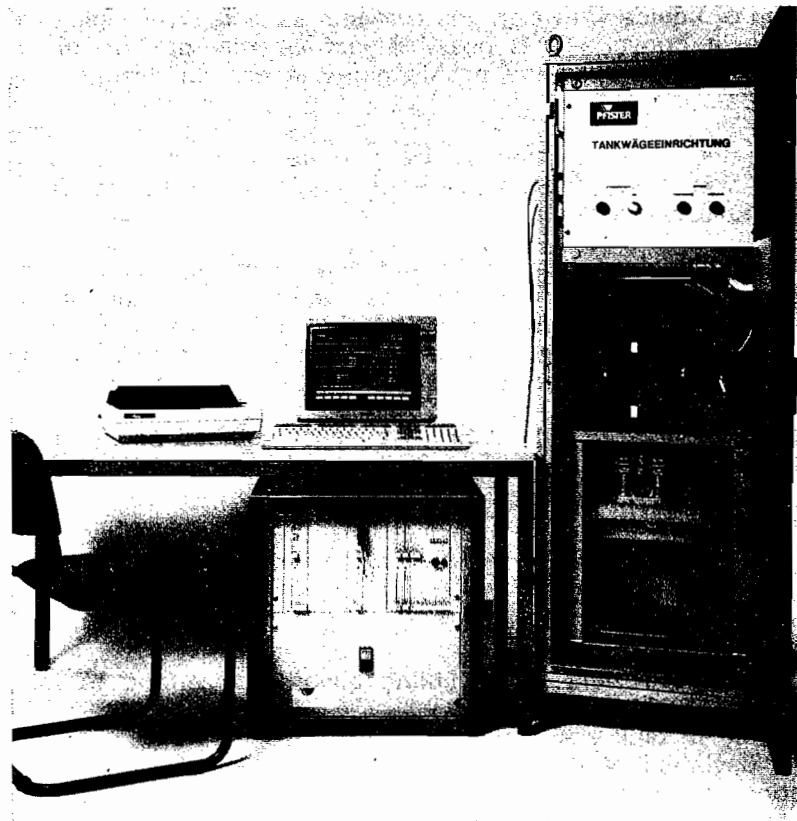

Fig. 3 — Tank weighing device installed in control room

The hydrostatic pressure at the tank bottom is transmitted to a gas column (Fig. 1) by means of a bubble system. A very small quantity (approx. 1 to 5 L/h) of air or inert gas (N_2 or CO_2) escapes from an oblique opening of the bubble pipe. The hydrostatic pressure being transferred is taken over by a separate pressure line above the upper edge of the tank by the bubble pipe. This pressure line (approx. 10 mm dia.) transfers the hydrostatic pressure loss-free to the weighing device, which can be up to 1 000 m distant from the tank. As an upright air column exists in the pressure line, no frictional losses occur.

In order to compensate for influences due to floating roofs and gas pressures, a differential pressure measurement is performed. For this purpose a separate pressure line is connected to the gas room of the tank above liquid level, which transfers the gas pressure to the weighing device free of losses as well. The end of this pressure line leading into the tank can also be run with dry air (dew point — 40 °C) if inflammable liquids are concerned.

Numerous tank units can at choice be connected to the weighing device by a selector switch (Fig. 4). For this purpose valves are installed in the pressure line for the hydrostatic pressure and for the pressure from the gas room above liquid level and also in the bubble gas lines of each tank.

If inflammable liquids are concerned the measuring device is designed in accordance with the German prescriptions for inflammable liquids. For example, the tank weighing device described can be used for inflammable liquids of dangerous materials classes A1, AII and B and the bubble gas line in zone 0 of the tanks.

The weighing of liquids with high gas contents as well as of highly frothing liquids (fermenting tanks in breweries), is possible just as well as that of highly viscous liquids and muds; in this case the bubble gas line can be supplemented by a diaphragm chamber.

Furthermore, the tank weighing device can be used for the mass-proportional mixing of liquids from several tanks (mixtures, dispersions) and for liquids and solid substances (solutions, suspensions).

A far-ranging field of application for the tank weighing device is that of ships' tanks. It covers weighing of the total ship mass and the determination of the draught, the control of the trimming by control of the ship position and the controlled filling of the ballast tanks, the determination of the potable water and fuel store (oil temperature 120 °C) as well all the freight tanks (Fig. 5).

Tank weighing devices of this type have been installed and pattern-approved in the Federal Republic of Germany and in Switzerland.

Examples

- Unit 1 — Product : Chloroform
Density : 1 497 kg/m³
Tank contents (max) : 1 133 t
Comparison measurement :
7 tank wagons were filled. Filling quantity according to rail weighbridge (d = 50 kg) 399.9 t,
according to tank weighing device 399.3 t,
i.e. a deviation of — 0.15 % along with fluctuations of the contents indication by approx. ± 100 kg due to technically required circulation within the tank.
- Unit 2 — Product : Heavy fuel oil
Tank contents (max) : 20 000 t
Distance tank to tank weighing device approx. 500 m
Within a period of 4 weeks the tank was discharged and refilled every day with between 0.12 and 6 % of the tank contents. For a total discharge of 15 % the following deviations were found compared to the values measured on a truck weighbridge :
with respect to the tank filling level ≤ 0.08 %
with respect to the range of the tank weighing device ≤ 0.02%.
- Unit 3 — Product : Derv (diesel oil)
Tank contents (max) : 6 500 t
9 tank wagons were filled, the weighing with a rail weighbridge resulting in a total of 518.00 t.
Measured value at the tank weighing device 518.40 t.
Considering the air buoyancy correction the difference amounted to 0.20 t, i.e. 0.04 %.

The above-mentioned measuring uncertainties can even be reduced by optimizing the tank table by using the tank weighing device and a vehicle weighing device as calibration standards.

5 — Advantages and characteristics as compared to conventional methods

The determination of the volume of liquids at rest by means of volumetric measuring methods is state of the art with regard to measuring instruments on the market which are subject to mandatory verification. On the one hand filling level measuring instruments with floats (displacers) and on the other hand more or less elaborate volume meters are used during filling and discharging [5]. Within the European economic field sometimes measuring systems with pressure transmitters as primary

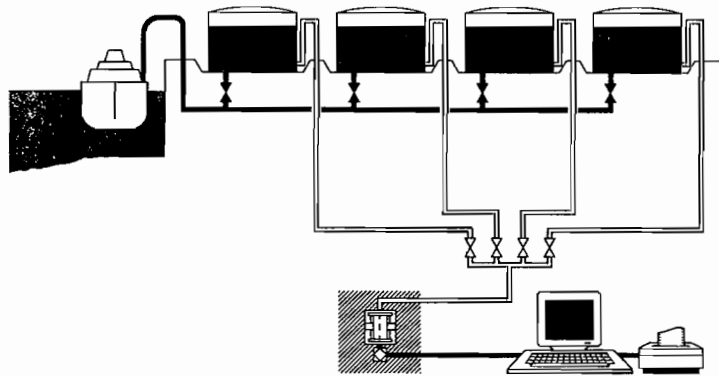

Fig. 4 — Interconnection of several tanks and tank weighing device

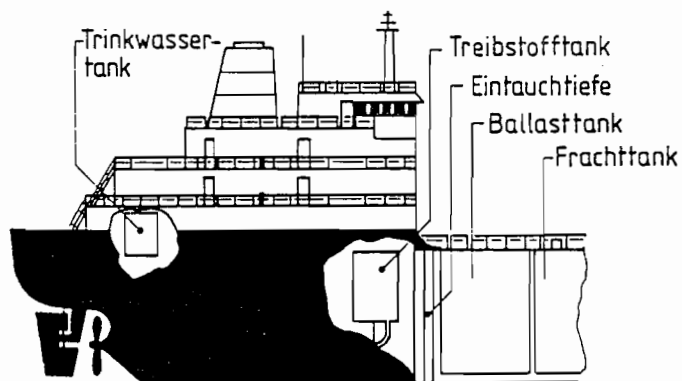

Fig. 5 — Tank weighing device on ships

- Trinkwassertank = potable water tank
- Treibstofftank = fuel tank
- Eintauchtiefe = draught
- Ballasttank = ballast tank
- Frachttank = freight tank

elements are used, which, however, do not have a pattern approval in most of the states due to metrological uncertainties.

The measuring device for the determination of the mass of liquids at rest developed by the manufacturer Pfister, Augsburg, West Germany, offers decisive advantages as compared to the conventional methods mentioned above. The advantages are in particular that it avoids the uncertainties in the measurement of average density and average temperature of the volumetric measuring systems which are presently subject to pattern approval.

The disadvantages of the measuring systems such as zero drift, variations of the linearity and risks of errors due to fouling and clogging of pressure diaphragms do not occur due to a control unit integrated in the system, by which the mechanical measuring component as well as the electronic weighing unit is automatically controlled by application of a test weight at any chosen time (normally every 24 hours). The tank weighing device can be supplemented by a density measuring unit so that apart from the mass a highly accurate indication of the volume is permanently possible.

Literature

- [1] Frieber, A.: Un procédé optique pour l'étalonnage des récipients-mesures de stockage des liquides. Bull. OIML Nr. 23, p. 33 (1986)
- [2] Lotmar, W.: Die Ausmessung der Ölbehälter der "Raffinerie du Rhône" bei Collombey (VS). Schweiz Bauzeitung 82, 749 (1964)
- [3] Hengstenberg, J.; Sturm, B. und Winkler, O.: Messen, Steuern und Regeln in der Chemischen Technik, Bd. I, Springer-Verlag, Berlin, Heidelberg, New York (1989)
- [4] DIN 51 757 Bestimmung der Dichte (Testing of mineral oils and related materials, determination of density) Beuth-Verlag, 1984
- [5] Kohlrausch, F., Praktische Physik, Bd. 1: Mengemessung ruhender Fluide, S. 118, Teubner Verlag, Stuttgart, 23. Auflage, 1985
- [6] API-ASTM-IP petroleum measurement tables No 53 A for crude oil and 53 B for generalized petroleum products — Correction of observed density at 15 °C. These tables have been adopted by ISO (91/1 — 1982) and by OIML (R 63).

NEW WEIGHING CENTER at the OFFICE of WEIGHTS and MEASURES for LEGAL METROLOGY in WEST-BERLIN

by Dr. Dieter BAUMGARTEN

Eichdirektor, Landesamt für das Mess- und Eichwesen, West-Berlin

SUMMARY — The West German weights and measures regulations amended in 1975 to approximate those of the EC regarding error limits for weights require the purchase and installation of a substantial amount of technical equipment. Both special balances, called mass comparators, and air-conditioned, vibration-free facilities are necessary to be able to implement standards of high accuracy in measuring weights.

The West-Berlin Office of Weights and Measures has solved the problem with the availability of such facilities by using limited investment funds as well as keeping the cost of energy down for day-to-day operation of the equipment.

Introduction

In the Federal Republic of Germany, verification is mandatory for weights of any kind used in commerce and legal trade, in medicine and in the manufacture and testing of pharmaceuticals, as well as for balances and scales used in conjunction with such weights.

Testing and verification of these weights and weighing instruments are done at legally prescribed intervals by the authorities responsible for legal metrology in the Federal Republic of Germany. Different accuracy requirements are established according to the particular application of the measuring equipment. These requirements are individually governed by the West German weights and measurements regulations.

The objective of the European Community Council Directive issued on 26 June 1971 for approximation of the laws of the member states relating to the common regulations on measuring equipment and on measuring and test procedures (Official Journal of EC No. L 202/1) was to harmonize the member nations' weights and measures legislation on legal metrology as much as possible. Since an optional solution to the EC harmonization effort was chosen, national regulations have remained in effect along with EC regulations.

As a consequence of the approximation of national laws to EC regulations, the West German weights and measures regulations had to be revised. The following regulations for weights resulted from such revisions :

The weights listed below are only accepted for national verification :

- Commercial weights (class M3) and
- Carat weights.

The following weights are accepted for initial verification both on a national level and within the EC :

- Weights of the accuracy classes E₁, E₂, F₁, F₂ and M₁ ;
- Cylindrical weights of the average accuracy class ; and
- Cube or block-shaped weights of the average accuracy class.

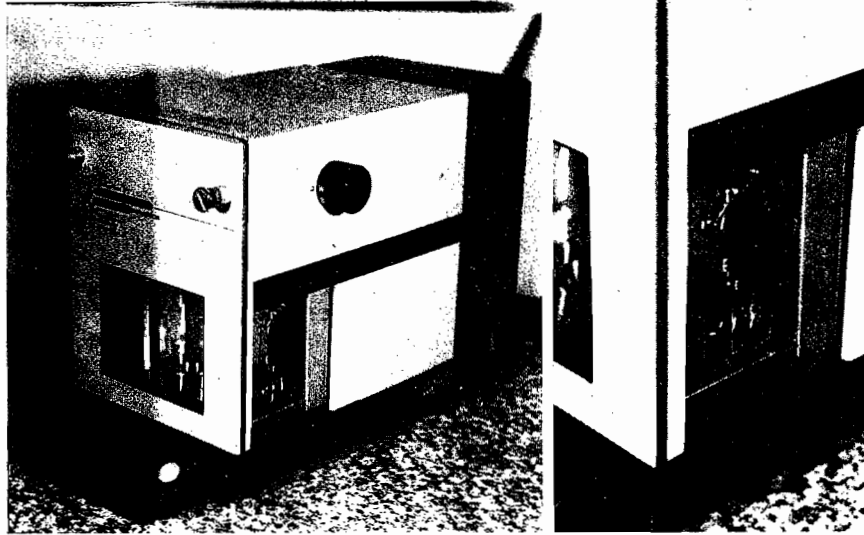

Figure 1 Mass comparator, Capacity : 5 g, Readability : 0.1 μg
The loading pan is automatically extracted sideways.

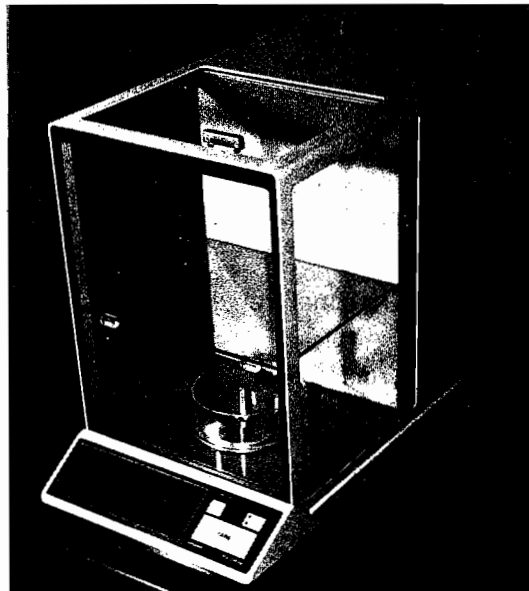

Figure 2 Mass comparator, Capacity : 50 g, Readability : 2 μg

The new accuracy classes, also referred to as error limit classes, resulted in a considerable restriction of the permissible error limits of weights to some extent. As a consequence of these changes in the regulations, the balances and reference standards for weights used so far by the Berlin Office of Weights and Measures no longer met the technical weights and measures requirements.

In addition, the lack of appropriate equipment resulted in technical problems, because when the new regulations went into effect, the balance-making industry was not prepared to offer the appropriate mass comparators by any means. Moreover, secondary problems have always occurred during the installation of sensitive balances and mass comparators since fluctuations in the ambient conditions and vibrations within a building must be reduced to a minimum.

Furthermore the financing of the entire equipment and upgrading of the premises represents investments that can only be made on a long-term basis.

Weighing Rooms

Because of exposure to direct sunlight, only one room of the ones available at the Berlin Office of Weights and Measures was basically suitable for mass comparison. However, to ensure the availability of these premises for such testing and verification throughout the year, extensive installation work would have been necessary to air-condition this room.

The cost involved in installing such air-conditioning equipment was substantial. Adding to these financial woes, there was concern that the investment might fail, as it did not cover the elimination of noise, convection on account of non-uniform temperature, and drafts, which are interfering factors that cannot be ignored.

After thorough considerations were made and the other available air-conditioned rooms were assessed, a different solution was chosen: three adjacent rooms, each having a volume of approx. 130 m³, were constructed on the basement floor. The outer walls of these rooms are located completely underground. The walls are more than 50 cm thick so it was assumed that the temperature would remain relatively constant throughout the year. Ducts from the central heating system in the remaining part of the building were not connected. Windows glazed with three insulating layers were installed in tight-fitting window frames. The available ducts allowed installation of an external air conditioner as required at a later date. According to the experience gained so far, however, an air conditioner is not necessary.

Furnishing the Rooms with Weighing Equipment

It was impracticable to furnish the rooms with balances or scales of the commercially available designs for mass comparisons of E₂ to E₁ weights. Rather, it was necessary to resort to the use of special makes of equipment. When the new rules of the West German weights and measures regulations went into effect in 1975, however, the officers of legal metrology in Berlin discovered that the industry was not able to offer mass comparators of the high precision needed.

The same applied to the mass standards required. Therefore, the regulations were well ahead of the state of the art available. Be as that may, the governments's common practice of extending investment planning to five years proved to be an advantage.

The only drawback was the industry's lack of general interest in manufacturing the special mass comparators of the required specifications. The reasons for this were probably the limited number of customers, high R&D outlay and the low unit sales volume anticipated.

The industry underestimated the consequences that the development of advanced measuring technology inevitably would have: innovations which, in turn, would automatically lead to additional innovations on the manufacturing sector itself.

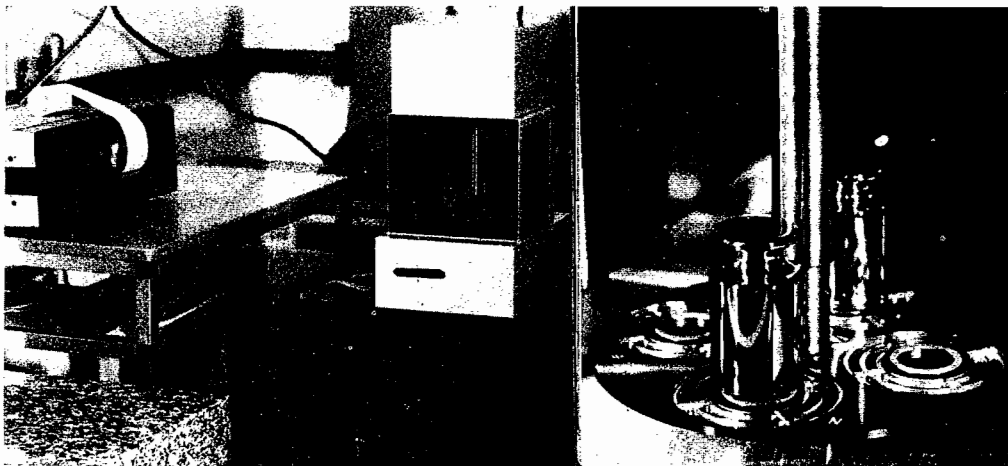

Figure 3 Mass comparator with a load alternator, Capacity : 1 000 g, Readability : 2 μ g
Two up to four weights each can be placed on the load alternator of the mass comparator for alternate loading and removal in the sequence pattern : standard mass - test weight. Computer and printer are shown to the left.

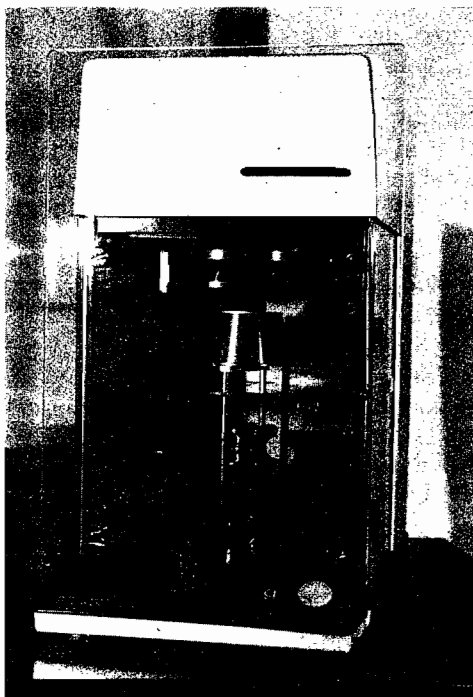

Figure 4 Mass comparator, Capacity : 2 000 g, Readability : 0.1 mg

Obviously, this situation has remained the same in recent times. Just two years after the standard mass laboratory in Berlin began operating, rather extensive damage caused by heater water leakage made it necessary to replace almost the entire number of balances for mass comparison, without any suitable alternative equipment available at that time. However, further development on the balance sector made remarkable progress within about the next 3 years. As a result, even higher accuracy can be achieved at present, without entailing great financial expense.

To test and verify very accurate weights, the Berlin Office of Weights and Measures currently uses nine balances. Seven of these are mass comparators which are available only for weights of a certain mass.

The specifications for each of these mass comparators and balances are as follows :

Balance No.	Fig. No.	Loading Capacity	Readability
1	1	5 g - 2 g - 1 g - 500 mg - 200 mg - 100 mg - 50 mg - 20 mg - 10 mg - 5 mg - 2 mg - 1 mg	0.1 µg
2	2	50 g - 20 g - 10 g	0.001 mg
3	—	500 g - 200 g - 100 g	0.01 mg
4	3	1 000 g - 500 g - 200 g - 100 g	0.002 mg
5	4	2 000 g - 1 000 g - 500 g	0.1 . mg
6 *	5 + 6	10 000 g - 5 000 g - 2 000 g	0.1 mg
7	—	20 000 g - 10 000 g	1.0 mg
8	—	Maximum load 200 g	0.01 mg
9	—	Maximum load 2 000 g	0.1 mg

Balances, nos. 1 through 7 are mass comparators

Balances, nos. 8 and 9 can be used for any weights that do not conform to the legally prescribed OIML nominal mass values.

This balance and mass comparator equipment is sufficient for performing all the required weighing procedures. However, it is foreseeable that it will have to be supplemented with an instrument for 50-kg weights of at least class F₁ accuracy since the industry has developed correspondingly accurate mass comparators with a higher maximum loading capacity.

Evaluation of the data measured can be done automatically with an on-line computer and a printer. These devices can be interfaced with all mass comparators.

This computerized system is also used to check the drift of mass comparator readouts in relation to changes in temperature and humidity. Based on such long-term measurements, it has been demonstrated that it is practical to shut off humidifiers and dehumidifiers before high-precision testing is begun for weights of accuracy classes higher than E₂. However, this does not have any significant effect on maintaining the constancy of the humidity.

* Note by BIML : A detailed description in German of the 10 kg-mass comparator is given in PTB-Mitteilungen 4/88, August 1988, pages 247-252. All the mass comparators described are manufactured by Sartorius GmbH, D-3400 Goettingen, Federal Republic of Germany.

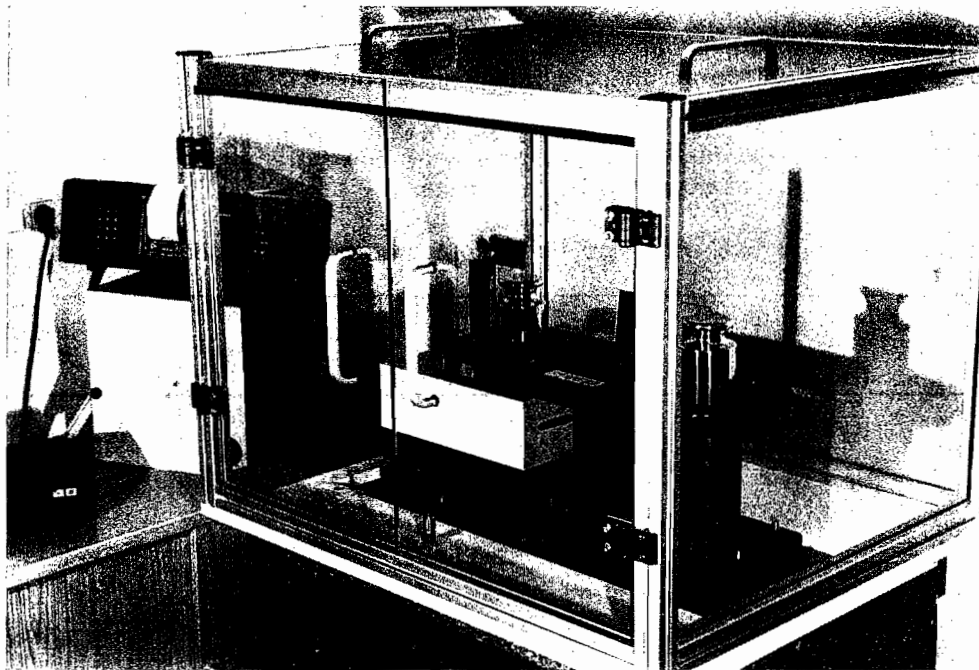

Figure 5 Mass comparator with a load alternator, Capacity : 10 kg, Readability : 0.1 mg

The mass comparator is connected to a computer and automatically performs preprogrammed series of measurements. Following each series, a hard copy of the data is printed out (printer on the left). The high sensitivity of the mass comparator makes it necessary to use a glass draught shield chamber. Longer series of measurements can be done at night without operator attendance.

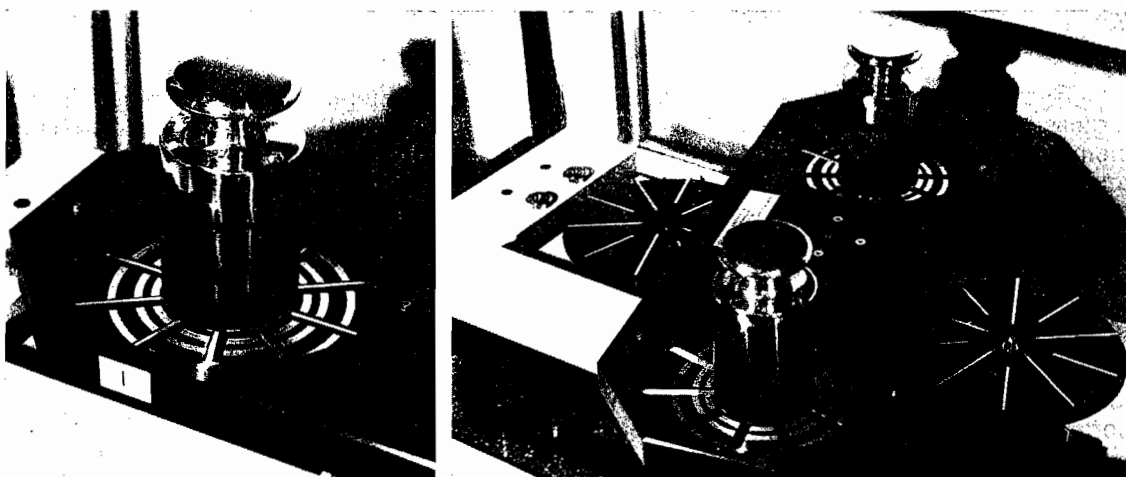

Figure 6 Detail of 10 kg-mass comparator showing how the load alternator platform is lowered for weighing a sample. As the platform is lowered, 10 radially positioned fins on the weighing pan are raised up through the slits on load alternator platform disc and take up the weight.

Mass Standards

Not only mass comparators but also the appropriate mass standards are needed to test and verify highly accurate weights. The following standards are presently available : set of weights from 1 mg to 1 kg, and 2 kg, 5 kg and 10 kg class E₁ weights. In addition, error limit class E₂ weights with nominal mass values of 20 kg and 50 kg, resp., are obtainable.

Air Conditioning of the Weighing Rooms

The rooms on the basement floor have a very uniform temperature that is around 18 °C in the winter without heating and about 20 °C in the summer. Only incandescent lighting fixtures are used to heat the rooms. They are operated predominantly in the infrared range as the result of a reduction in voltage. The number of persons working in each weighing room is allowed for in controlling the heat generated by turning the lighting fixtures on and off (100 watts/person). Therefore, controlling the heat is relatively simple and guarantees a temperature that remains constant within ± 0.2 °C.

Controlling the humidity is more problematic. At a given relative humidity of 50-60 %, approximately 2 L of condensed water is produced every 24 hours in the summer ; in the winter, by contrast, approx. 6.5 L of water vapor is absorbed by the air every 24 hours.

For continuous operation, this means that approximately 20 L of water must be available in the room humidifier on the weekends, for example, in order to permit around-the-clock operation.

After various tests were performed to determine the optimal equipment configuration for controlling the humidity, one humidifier and two dehumidifiers are used. The controllers in the room take care of automatically turning the equipment on and off. In the winter, the dehumidifiers are operated merely as ventilators to avoid the formation of layers of air, each having different temperatures, which causes convection.

As opposed to temperature, the humidity can only be controlled approximately. Fluctuations in the room humidity of about ± 3 % compared with the nominal humidity do occur during the 15 minute humidification phase which must be repeated every three to four hours.

Air-conditioning of rooms not only entails a high capital outlay, but also a high energy bill for running the air conditioners. To determine the actual energy requirements, the entire energy consumption for the weighing rooms is measured by a separate meter.

Over a 4-year period, a total of 16 000 kWh of energy were consumed at the Berlin Office of Weights and Measures. At a kilowatt-hour rate of 0.35 DM/kWh in Berlin (about 20 cents in U.S. currency at an exchange rate of 1.90 DM to the \$), this translates to a monthly electricity bill of only DM 116 (\$ 61). Of course, it must be kept in mind that this amount includes the electricity needed to energize the lighting fixtures and the equipment.

Weighing Results

The mass comparators used at the Berlin Office of Weights and Measures are adjusted to test and verify E₂ weights. In the process, it is very important to minimize the test times as far as possible. Since highly accurate weighing takes an extraordinarily long time, reducing this time to boost efficiency can be done only by decreasing the number of repeat weighing operations. The considerations in such time reduction are as follows :

Testing weights of accuracy class E₂ or higher requires mass comparators that can reproduce given weight readouts within tight tolerances as often as desired.

Since repeat comparisons on a mass comparator with a sufficiently high display resolution inevitably yield variations in the readouts, the amount by which the individual readouts vary from the arithmetic mean of several measurements determines whether a mass comparator is suitable for a range of nominal mass values. The standard deviation is used as the measure to assess the degree of such dispersion. If the standard deviation is known from a test series and if it has been established that the basic pattern of all mass values measured shows normal distribution, the standard deviation from one or several measured values can be used to deduce the uncertainty of measurement of a nominal mass readout for comparison.

If n measurements are made instead of only one for a weight, the following equation will be obtained for the random component of the uncertainty

$$U_A = \pm \frac{t}{\sqrt{n}} \sigma$$

U_A = statistical uncertainty of the result of measurements

t = coefficient (1, 2, 3...) related to the desired statistical reliability

σ = standard deviation of the mass comparator

n = number of repeat measurements of mass for a weight undergoing testing and verification.

As the number of repeat measurements increases, the uncertainty of measurement will decrease by a factor of $1/\sqrt{n}$.

Based on these facts, the number of weighing operations required to test an individual weight can be determined when the standard deviation is known and the statistical reliability of the result is given. As a matter of principle, it is understood that the uncertainty of measurement U_A of a mass comparison may not be greater than one third of the permissible error E of the test weight.

$$U_A = \pm \frac{t}{\sqrt{n}} \sigma \leq \frac{1}{3} E$$

In practice, it is assumed that $t = 3$ corresponding to a statistical reliability (confidence level) of at least 99 % provided that the characteristic standard deviation of the mass comparator has been determined from a great number of measurements with the same load. If the equation is solved by introducing $t = 3$, the minimum number of repeat measurements that are necessary will be

$$n \geq \left[\frac{9\sigma}{E} \right]^2$$

If the standard deviation of a mass comparator is $\sigma = 1/5 E$, $n \geq 3.24$ will be obtained. This means a total of four weighing operations is necessary to achieve the required statistical reliability for the mean value.

The random component of the uncertainty of the measured value in this case will be

$$U_A = \pm \frac{t}{\sqrt{n}} \cdot \sigma = \pm \frac{3}{\sqrt{4}} \cdot \frac{E}{5} = \pm 0.3 E$$

If the number of measurements is increased from four to ten, the uncertainty of measurement will decrease to $U_A = \pm 0.19 E$.

Each of the mass comparators and balances underwent thorough testing to determine the reproducibility of the readouts for the values measured. Besides helping to determine the standard deviation, a plotter was able to record the readout stability

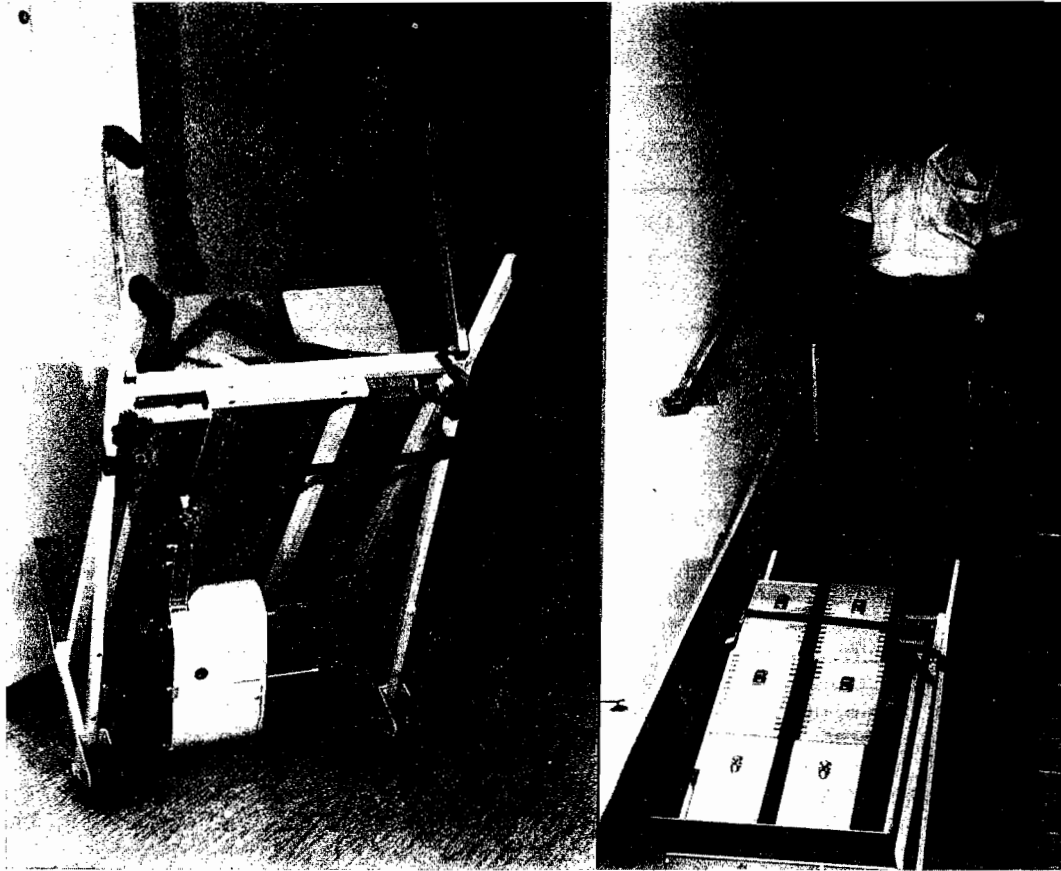

Figure 7 Electrically powered cart that can go up and down the stairs. Special handles allow it to be expanded so that weights can be moved up and down the stairs without the user having to assume an unnatural body posture.
The motor for driving the cart and the rechargeable batteries are located in the light-colored housing between the wheels (left). The power switch is on the upper right handle.

in a graph. Evaluation of the data measured by the mass comparators yielded the following results :

- a) The standard deviation for all mass comparators is less than one fifth of the error limit of E_1 weights. Based on the relations

$$E(E_1) = \frac{1}{3} E(E_2)$$

where

$E(E_1)$ = the permissible error of a class E_1 weight and

$E(E_2)$ = the permissible error of a class E_2 weight.

we find that only one mass determination of E_2 weights is sufficient, with the random component of the uncertainty of measurement being

$$U_A = \pm \frac{t}{\sqrt{n}} \sigma = \pm \frac{3}{\sqrt{1}} \cdot \frac{1}{5} \cdot \frac{1}{3} E(E_2) = \pm 0.2 E(E_2)$$

- b) The standard deviation of the mass comparators is in fact in several cases even lower than one fifth of the maximum permissible error of E_1 weights and acceptable results in comparisons of such weights can thus be obtained by performing just a few weighing operations (n) according to the following table :

n	Weight
1	100 mg - 500 mg - 1 g - 2 g - 5 g 10 g - 20 g - 50 g - 100 g - 200 g 500 g - 1 kg - 2 kg 10 kg - 20 kg
2	50 mg - 200 mg - 5 kg
4	1 mg - 2 mg - 5 mg - 10 mg - 20 mg

Special Device for Transporting Large Weights

Since the mass standards laboratory is located on the basement floor, transportation of the weights must be done using special means. The Berlin Office of Weights and Measures decided to use an electrically operated transfer cart that can go up and down the stairs (see Figure 7) because the elevators are permanently installed at the stairwells and it would have cost too much to change their location. The cart with bags for protecting the weights can be moved up and down the stairs by the electromotor powered by rechargeable batteries. In the process, a crank mechanism lifts the load from step to step. Featuring a carrying capacity of 200 kg, the cart can negotiate approximately 8 stories of staircases without the batteries having to be recharged. With a price tag of 3 750 DM (U.S.\$ 1 815.78), the cart, when used extensively provides considerable advantages over using a stairwell elevator.

Conclusions

The expectations concerning the measuring accuracy of the mass comparators used have been met completely. In a few cases, the performance of these mass comparators well exceeds the requirements placed on them. On the one hand, this demonstrates the performance capabilities of the balance-making industry and, on the other hand, provides the user with an additional cost benefit because the mass comparators reduce the time it takes to weigh. As a result, this also makes an impact on the Office's productivity, allowing officers of metrology to process verification and testing applications faster.

FRANCE

CALIBRATION of TANKS by INTERNAL OPTICAL METHOD *

by P. CANAVAGGIO and P. DEMANY

Sous-direction de la métrologie, Paris

SUMMARY — This paper describes the new system now used by the French legal metrology service for gauging of reservoirs. Previously a system requiring two theodolites was used but not found convenient for gauging ship reservoirs due to the movement of the tank and the necessity of maintaining a fixed distance between the two instruments.

The new system uses one theodolite with electronic reading of horizontal and vertical angles on which the sight tube is equipped with a direct distance measuring laser. The instrument when installed inside a tank has a repeatability of about 3 mm and does not require any reflector for measuring short distances.

This theodolite is connected to a computer and data system which with specially designed software, allow direct evaluation and recording of tank volume from a number of measurements taken on the various tank surfaces. For the purpose of computation these surfaces are divided into individual elements (plane, cylinder, annulus, spherical cap. etc.). The coordinates of the theoretical model of each surface element are computed from the actual measurements by using the method of least squares.

RESUME — Cet article décrit le nouveau système utilisé pour le jaugeage des réservoirs par le service français de métrologie.

Précédemment, une méthode utilisant deux théodolites était employée mais elle s'est avérée difficile à appliquer pour le jaugeage de réservoirs de bateaux à cause des mouvements de ceux-ci joints à la nécessité de maintenir une distance fixe entre les deux instruments.

Le nouveau système n'emploie qu'un seul théodolite mais qui est équipé des systèmes de lecture électronique des angles horizontaux et verticaux, et sur lequel le tube de visée est pourvu d'un laser modulé permettant les mesures directes de distances. Lorsqu'il est utilisé à l'intérieur d'un réservoir, l'instrument permet d'obtenir une répétabilité de la mesure de l'ordre de 3 mm et ne nécessite pas l'emploi d'un réflecteur pour de courtes distances.

Le théodolite est relié à un micro-ordinateur qui permet à l'aide d'un logiciel spécialement élaboré, l'évaluation directe et l'impression du volume du réservoir (barème) à partir d'un certain nombre de pointés sur les différentes surfaces du réservoir.

*Ces surfaces sont, pour les besoins du calcul, divisées en éléments individuels (plan, cylindre, virole, coupe sphérique, etc.). Le mode de calcul utilise la méthode des moindres carrés afin de déterminer à partir des mesures effectuées, les coordonnées du modèle théorique de chacun de ces éléments **.*

1. The problem

The exact determination of the quantities of liquid (oil products, liquified gases, chemical products), purchased, stored, transported or sold has, owing to its obvious financial consequences, become a primary concern of the parties involved.

[*] Presented at the OIML seminar on Calibration of Liquid Volume Measuring Installations, Arles, France, 11-15 May 1987.

[**] Des copies de la version française de cet exposé peuvent être obtenues du BIML.

To a great extent this determination is made by measuring the large tanks which are designed to contain these products (storage tanks or ship tanks). These tanks, when a strict metrological control is made on them, referred to as calibration, can be used with tables which indicate the volumes contained depending firstly on the position of the level, and secondly on the value of certain influence quantities (temperature, density of the product). The relative error as to the capacities indicated in these documents should not exceed $\pm 0.3 \%$.

The calculation of these numerical tables is based on the determination of the internal geometrical characteristics of the tanks calibrated, with a measurement uncertainty of a few millimetres.

In buried and heat insulated tanks, or those located in the hull of ships, this determination until recently made use of steel tapes graduated in millimetres and calibrated at a reference tension and temperature. This method, simple from the metrological point of view, nevertheless has two major drawbacks :

- the installation of complete and very costly scaffolding, in view of reaching points on the wall distributed over the height of the tank and which could be up to 30 metres high
- the accomplishment of dangerous acrobatics made necessary by the need to stretch the tape between special points the positions of which depend on the geometry of the tank.

These reasons have entailed seeking methods of calibration whereby, whilst preserving the necessary precision, the drawbacks described above could be remedied, and offering the possibility of making the measurements from the bottom of the tank. Quite naturally the optical methods were considered in view of meeting this concern.

2. Initial approach

The problem was as follows : as the tanks concerned are not of just any form but always composed, a priori, of theoretically well defined surface components such as planes, horizontal or vertical cylinders, spherical caps, portions of annulus, ellipsoids, etc., how can the real geometrical characteristics of these surfaces be grasped, which are always different from their theoretical characteristics ?

The principle of the solution adopted consists in examining each element by "sowing" points on them whose coordinates can be determined in a space reference. Data processing of the points thus obtained indicates the elements required which characterize each surface. Finally by juxtaposing these latter the whole of the tank can be reconstituted.

In practice firstly a set of points was generated on the internal surface of the tanks, using a couple of precision theodolites (graduation step of the circles : 1/10th of a milligrade) *.

In this so-called triangulation method the measurements are facilitated by equipping one of the theodolites with a laser emitter whose beam constitutes the optical axis and creates on the tank wall an impact of sufficient definition to be sighted by the telescope of the other theodolite (see Figure 1). This luminous impact constituting the point observed, is defined by two sets of angular co-ordinates (α_1, β_1) and (α_2, β_2). This method which, used in cylindrical and spherical tanks, still gives excellent results, nevertheless requires :

- conveying to the bottom of the tanks, a laser, two theodolites, two tripods, together with the equipment necessary to determine, by optical method, the value of the base "B" with sufficient accuracy,

(*) The grade or gon is the commonly used unit of angle in surveying and is equal to 1/100 of the right angle (90°). One milligrade or milligon is therefore equal to 3.24" (angular seconds). The designation ° and ′ found in some literature represents respectively 10⁻² and 10⁻⁴ gon.

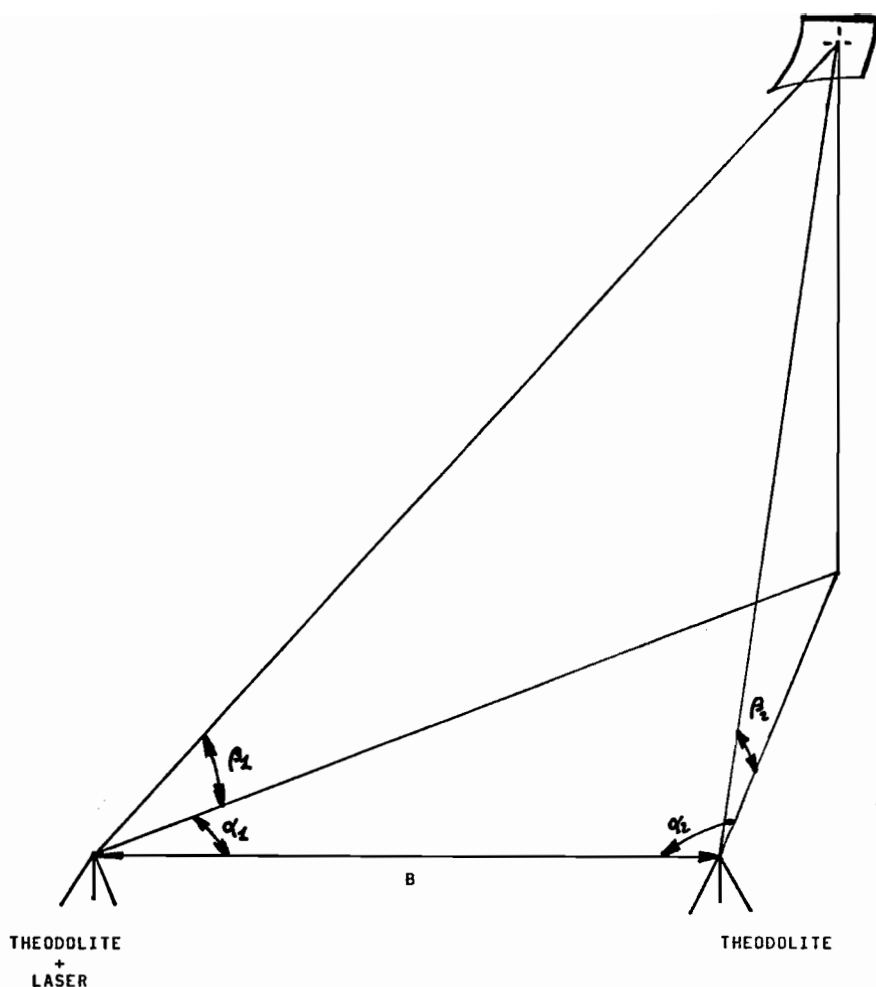

Fig. 1 — Measurement by optical triangulation with two theodolites on the same level : the position of the impact point of the laser beam on the tank wall defined by the distance B , the horizontal angles α_1 and α_2 and the vertical angles β_1 and β_2

— marking very carefully, the respective position of each of the theodolites in the space reference linked to the other. This very delicate operation also requires perfect stationing of the apparatus and practically rules out the use of this method in the tanks of a ship afloat, even in still water, owing to the movements of the hull.

Although the development of digital processing theodolites capable of being linked, two by two, directly to a microcomputer during the measurements, has facilitated this reciprocal positioning, it has not reduced the number of apparatuses to be employed on the bottom of the tank, whose access is often very difficult. The targets to attain were thus firstly to simplify the implementation of the optical measuring system and secondly to be no longer constrained by the possible movements of the tank.

3. The solution

The use of a precision theodolite with a scale interval of the circles equal to or less than 1 milligrade, and which would also be capable of measuring the distance between any point sighted, would solve these problems by applying a system of spherical coordinates (see Figure 2) :

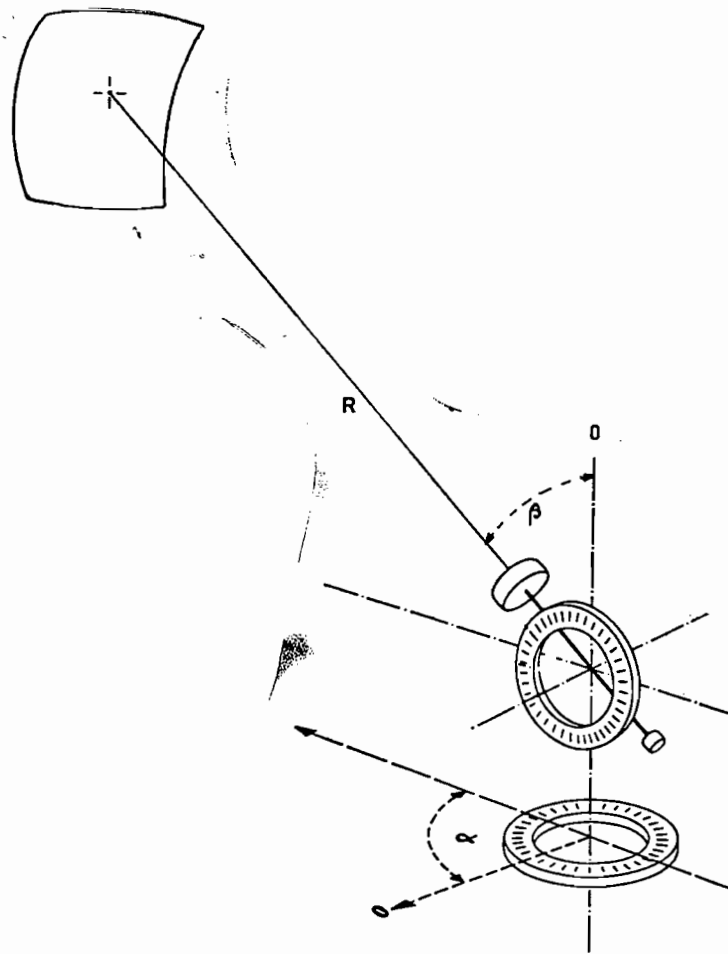

Fig. 2 — Measurements with the IMS theodolite : position of the impact point of the laser beam on the tank wall defined by the spherical coordinates R , α , β

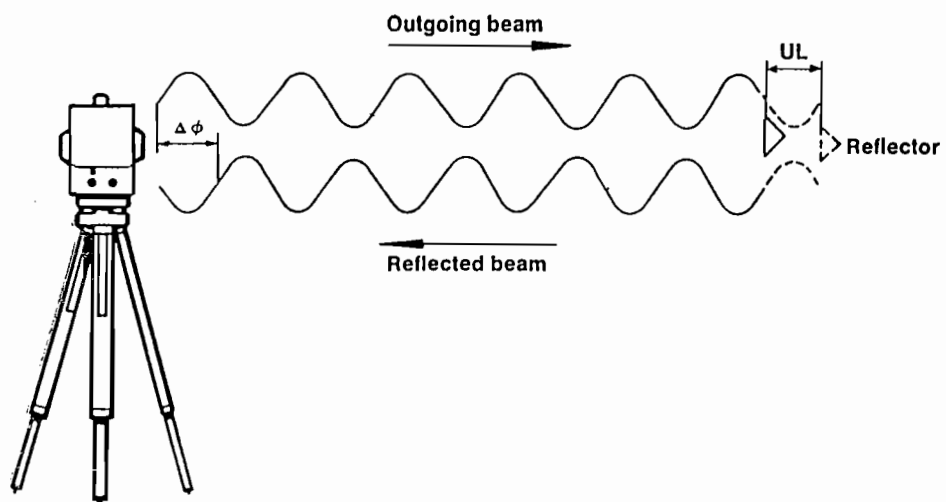

Fig. 3 — Principle of distance measurement with the IMS theodolite

- firstly by reducing to one the number of apparatuses employed on the site
- secondly by suppressing the problems of reciprocal positions of these apparatuses and movement of the tank.

The last constraint being that the apparatus remains set, no longer in relation to the true vertical, but in relation to the tank calibrated, the latter thus being free to oscillate.

The IMS theodolite manufactured by the GEOTRONICS company appearing to be capable of solving these problems, preliminary tests were made in June 1983 :

- on the calibration bench of a length metrology laboratory, as concerns accuracy of the distance measurements,
- in a vertical cylindrical tank already calibrated to determine the fitness of the apparatus for use on the site in this particular application.

As these first tests produced satisfactory results, it was decided to develop a complete calibration method using this type of apparatus.

Principle of operation

The instrument IMS 500 combines two main functions : it measures the horizontal and vertical angles and the direct distance from the theodolite to the point on which it is sighted.

The angles are measured by two photoelectric systems comprising discs with optical tracks which provide pulses that are counted and interpolated by an electronic unit.

The instrument can thus be used as an electronic theodolite and displays horizontal angles in scale intervals of $5 \cdot 10^{-4}$ gon and vertical angles in intervals of $1 \cdot 10^{-3}$ gon.

Distances are measured by the use of a helium-neon laser beam which is merged with the optical axis of the telescope. The laser beam is amplitude modulated at a fixed frequency by the use of a Kerr cell. When the beam strikes an obstacle chosen by the operator a part of the light is reflected back to the photoelectric receiver of the apparatus which measures the phase shift of the reflected light pulses in relation to those emitted (see Figure 3).

The phase difference $\Delta\phi$ will have identical values (or be zero) for every displacement of the target equal to UL . Generally we are :

$$2 UL = \frac{c}{f}$$

where f is the frequency of modulation and c the group velocity of electromagnetic waves in the surrounding air.

If the frequency of modulation is 29.97 MHz the unit length UL will be 5 m. The phase measuring technique allows interpolation down to a scale interval of 1 mm. The instrument is equipped with an automatic intensity regulation system which allows its use without special reflectors on most not completely black target surfaces up to a distance which may attain 100 m.

In geodetical surveying the same instrument can be applied for measuring distances of several kilometers by use of special reflectors. An additional much lower modulating frequency is provided for coarse distance measurements so as to produce automatically unambiguous results.

The simultaneous measurement of the horizontal and vertical angles and the distance thus directly determines, in one set of spherical coordinates, the position of the impact point of the laser beam.

Tests

After the previously mentioned preliminary tests, full acceptance tests of the apparatus were made in June 1984 comprising :

- a comparison with a length standard reference (laser interferometer) in the metrology laboratory, calibration of the "distance" function and adjustments. The systematic errors liable to be corrected were found to be less than ± 5 millimetres and the random errors (repeatability), less than ± 3 millimetres
- tests in the real conditions of use, in a tank of a ship being built on a shipyard. The tank, firstly carefully measured by a conventional tape method, was then calibrated by the optical method. The geometrical parameters of the tank deduced from both of the methods were then strictly compared: the differences did not exceed 3 millimetres in one direction or in the other, on values comprised between 2 and 10 metres (cylinder radii, annular or spherical forms, lengths on axis); the results of the tests were considered to be compatible with the target to be attained. The method of measurement was then improved, with the aid of experience, resulting in the following operating procedure.

Operating procedure

Each surface or surface element (plane, cylinder, annulus, spherical cap) forming the inner wall of the tank is dealt with separately: points are distributed on it with the IMS as homogeneously and as completely as possible. The spherical coordinates of each of these points (R, α, β) are converted into cartesian coordinates. Specially developed software then computes the characteristics of the theoretical surface of the same nature, passing through the points processed "as best as possible". The elements defining this surface are positioned via a space reference linked to the IMS, and stored in a memory in view of subsequent processing.

When all the surfaces have been processed, they can be assembled so as to reconstitute the whole of the tank and thus make the synthesis of its geometrical characteristics. These processing operations take place in situ via a portable micro-computer. The transfer required is made directly from the "geodat", data acquisition system, coupled to the IMS, in which the numerical values determined during the measurements are automatically stored.

4. Characteristics of tanks

The tanks are constituted by geometrical surfaces: planes, cylinders, spheres, ...

The most current types are:

- horizontal cylindrical tank with
 - cylindrical part
 - spherical or "basket handle" ends
 - secant (breakwater bulkheads) or parallel (biloop) planes
- vertical cylindrical tank with:
 - cylindrical shrouds
 - flat or tapered end.

Each geometrical element offers a certain number of degrees of freedom. They characterize the surface specifically (radius), or relatively (axis, position).

The assembly constraints have the effect of reducing the number:

cylinder	: 5 degrees of freedom
spherical/basket handle end	: 2 to 4 degrees of freedom
plane	: 2 to 3 degrees of freedom
shroud	: 3 degrees of freedom
flat/tapered end	: 1 to 5 degrees of freedom.

5. Principle of the data processing

For each geometrical part of the tank, the mathematical surface is determined whose sum of the squares of the distances to the measurement points is minimum :

$$\begin{array}{l} i = n \\ \sum \Delta_i^2 \rightarrow \text{minimum} \\ i = 1 \end{array}$$

Δ_i is the Euclidian distance.

This surface (S) is characterized by a certain number n_o of parameters (degrees of freedom).

The standard deviation in the distance of the measurement points to the theoretical surface is estimated by :

$$dt = \left(\frac{1}{n - n_o} \sum_{i=1}^{i=n} \Delta_i^2 \right)^{1/2}$$

This estimator is without bias. Its mathematical expectation is independent of the number n of points sampled whereby $n > n_o$. It represents the combination of the random measurement uncertainties and the surface deformations.

6. Uncertainty computation

The uncertainty computation is based on the assumption of homogeneous sampling: the points are considered as the centres of disjointed "influence surfaces", of the same area and whose sum is the geometrical surface element.

The distances between the measurement points and the theoretical surface — unknown surface, slightly different from the one estimated — are considered as being random, independent variables and with the same variances.

The uncertainty as to the volume is estimated by :

$$i_v = \left(\sum S^2 \left[i_s^2 + \frac{(k dt)^2}{n} \right] \right)^{1/2}$$

where

- Σ covers the whole of the surfaces of the tank
- S is the surface
- i_s is an assigned systematic uncertainty
- $k = 3$.

The assigned systematic uncertainty is assessed from the instrument's systematic distance uncertainty.

7. Results

The results are displayed on the screen of a portable microcomputer in two successive phases :

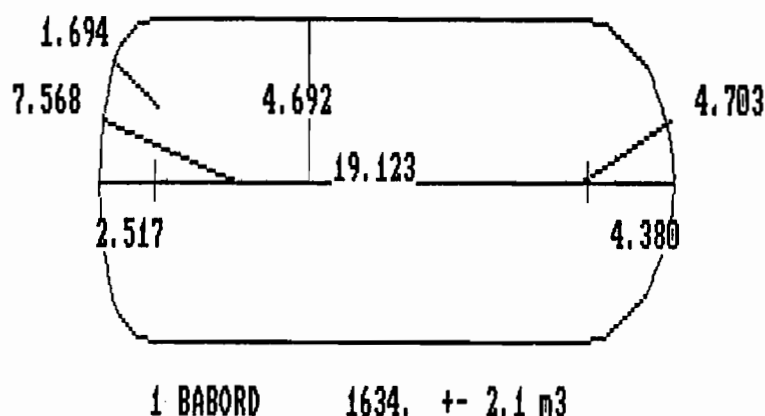

	S(m ²)	dV(m ³)	cV(m ³)	Nb	No	
CYL	564	0.73	0.00	40	50	I _s 0.9 m ³
CALAR	120	0.46	0.00	21	23	/V 0.5%
TORAR	49	0.32	0.04	14	13	I _t 2.1 m ³
CALAV	129	0.20	0.00	21	10	/V 1.3%
						I _o 2.0 m ³
						/V 1.2%

Fig. 4 — Microcomputer printout of the global result of the measurements showing the form of the tank, the numerical characteristics and the uncertainties

- each surface element is firstly processed separately to obtain :
 - its geometrical characteristics
 - its situation in relation to the system of axes used
 - the point sampling quality indicators
 - the distribution of the points over the surface elements
- when all the surface elements have been thus processed, the software recapitulates the tank. Thus a dimensional diagram is obtained covering all that is finally useful to know : numerical characteristics and uncertainties (see Figure 4).

8. Conclusion

The tank being calibrated and its real geometrical characteristics determined with the required accuracy, it is now necessary to establish the numerical tables whereby the quantity of liquid contained can be calculated contingent on the corresponding magnitudes : level, pressure, temperature, list, trim, density.

From the specific programs enabling these computations complete numerical tables are printed out which, formatted and bound, form the final documents sanctioning the calibration operations :

- table of volumes depending on the position of the level (20 °C)
- table of temperature corrections (tank steel)
- table of temperature corrections (level gauge system)
- table of corrections contingent on the density of the product contained :
 - immersion of the floating deck (if required)
 - immersion of the level gauge system float
 - swelling under the hydrostatic load (if required)

- tables of corrections contingent on the position of the tank :
list and trim (in the case of ships).

The calculation of the product quantities frequently made by depot officials or officers responsible for the cargo on ships, requires for obtaining accurate final results :

- a careful calibration of the tanks
- accurate and precise instrumentation covering the levels, pressures and temperatures, (the maximum permissible errors vary depending on the country)
- the availability of means for making a tedious numerical calculation, twice for each tank, in a minimum amount of time, on depots or ships often with about ten tanks.

The storage in a microcomputer located on board, or installed on the depot site, of all the numerical tables and presence of suitable processing software, fully automates the computation of the weights or volumes and practically eliminates the risks of error. This microcomputer, which can be connected by transmission to the instruments installed on the tanks, can then follow up, almost instantaneously, the evolution in the quantities of products received or delivered and finally supply, through a printing device, a synthesis document relating to the transaction performed.

The results of these computations can, on board ships, be associated to certain characteristics of the hull structure. The whole set of data thus formed, processed by suitable programs, allows to compute the expected stability of the ship at sea together with the stress to which it is subjected by its cargo.

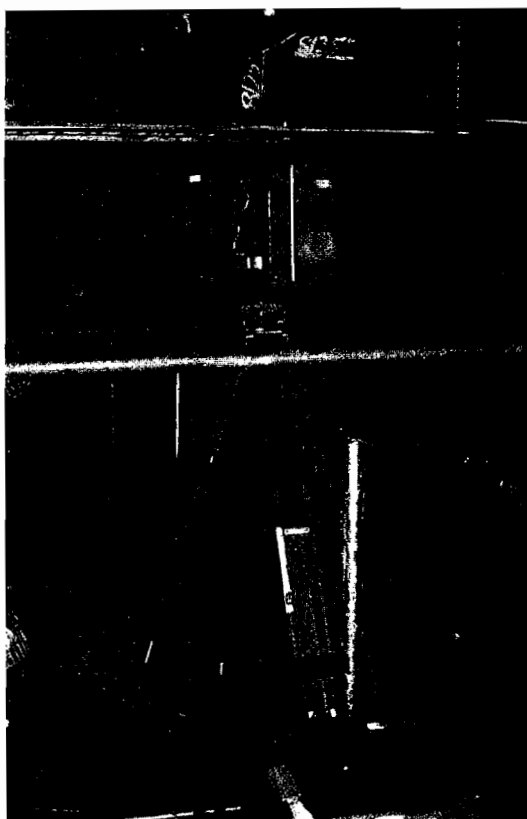
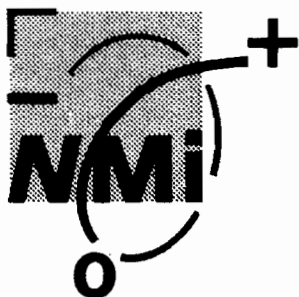

Fig. 5 — The IMS theodolite set up for measurements inside a ship tank

PAYS-BAS



L'INSTITUT NÉERLANDAIS de MESURES, NMI

par Gérard J. FABER

Sous-Directeur Général du NMI (*)

RESUME — Après approbation par le Parlement du Royaume des Pays-Bas, le service néerlandais de métrologie a été “privatisé” à compter du 1er mai 1989. La nouvelle organisation, appelée NMI (Institut Néerlandais de Mesures) est entièrement indépendante mais tout son capital en actions est en la possession de l'Etat. Le NMI est chargé de toutes les activités dans le domaine de la métrologie légale ainsi que du maintien des relations internationales dans le cadre des Communautés Européennes, de l'OIML et du BIPM.

Quelques données historiques

Depuis un certain nombre d'années le gouvernement des Pays-Bas mène une politique en faveur des privatisations. Le gouvernement s'est fixé les objectifs suivants :

- a) une fonction publique plus réduite mais mieux qualifiée
- b) l'amélioration de la position financière de l'Etat
- c) le renforcement du secteur privé.

En décembre 1984 le gouvernement prit une décision de principe sur la privatisation du “Ijkwezen”, c'est-à-dire le service de métrologie. Le service reçut l'ordre d'étudier, dans un délai de 6 mois, les conditions sous lesquelles une privatisation pourrait être appropriée. Les autorités du Ministère compétent, à savoir le Ministère des Affaires Economiques, et la direction du service arrivèrent à la conclusion que la privatisation était en effet réalisable, voire désirable, si les conditions suivantes étaient remplies :

- le service doit être privatisé dans sa totalité, c'est-à-dire que toutes les activités et compétences restent sous le même toit,
- il ne faut pas créer de séparation entre “décideurs” et “exécutants”,
- le service privatisé doit conserver toutes les compétences pour appliquer les lois dans le domaine de la métrologie.

Après de longues discussions parlementaires qui se terminèrent en décembre 1988, la date définitive de la privatisation fut fixée au 1er mai 1989. Le service s'appelle maintenant : Nederlands Meetinstituut (NMI).

Signification du terme “privatisation”

En fait, dans le cas du NMI, le terme “privatisation” est plutôt impropre. En général la “privatisation” comprend le transfert de tâches publiques à des organismes privés. Pour le NMI, l'expression “mise en position indépendante” serait plus appropriée, celle-ci indiquant parfaitement que l'institut d'origine continue toutes ses activités avec les mêmes responsabilités, mais que sa gestion est séparée de l'Etat.

(*) Monsieur G.J. Faber est nommé Directeur Général du NMI à compter du 1er janvier 1990, succédant ainsi à Monsieur J.M. de Wolf.

Caractéristiques du nouvel Institut

Lors de visites que j'ai effectuées auprès de services de métrologie de divers pays, j'ai pu constater que l'on a parfois une idée erronée du nouvel institut : est-il investi de l'autorité nécessaire ? Reste-t-il partenaire dans le circuit international ? Pour écarter tout malentendu, voici les caractéristiques principales du NMI :

1. Le NMI continue de constituer l'unique organe officiel de métrologie légale aux Pays-Bas.
2. Le NMI est officiellement chargé des approbations de modèle, des vérifications primitives et ultérieures des instruments de mesure ainsi que de la surveillance métrologique.
3. Le NMI est complètement mandaté par le gouvernement pour représenter le pays sur le plan international (CE, OIML, BIPM).
4. Le NMI constitue le bureau officiel des Pays-Bas pour les étalons nationaux.
5. Le NMI est chargé de la gestion et de la surveillance de la NKO (Organisation néerlandaise d'étalonnage).
6. Le NMI a l'initiative du processus de création de la législation métrologique.
7. Tout le capital en actions est entre les mains de l'Etat et celui-ci n'est pas autorisé à vendre ces actions sans l'approbation du parlement.

L'avenir

Le NMI est une organisation, relativement forte avec une bonne position financière. L'effectif est d'environ 300 personnes.

Pour l'avenir on s'attend à une croissance modérée grâce surtout à une augmentation du nombre des étalonnages. Les activités sur la base de la loi (approbations de modèle, vérifications) resteront au même niveau.

Le NMI est un institut de bonne réputation sur le plan européen. Sa direction est très confiante dans l'avenir et la "privatisation" a créé la possibilité de réagir de façon rapide et efficace aux besoins métrologiques qui se manifesteront dans la société des années 90.

Organisation du NMI

L'organigramme du NMI se compose de quatre unités (voir Fig. 1) :

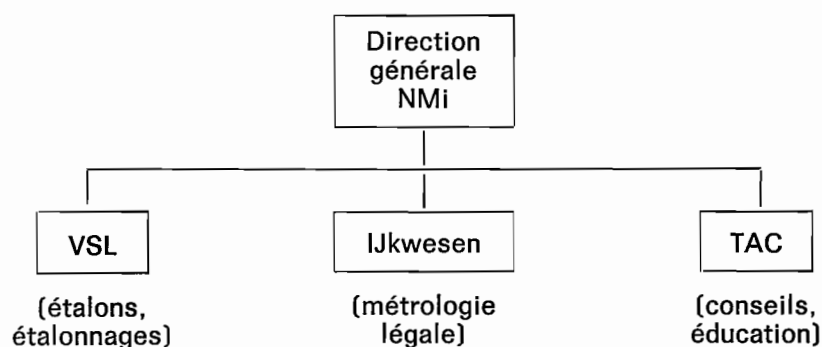

Fig. 1 — Organigramme du NMI

- La direction générale du NMI comprend environ 40 personnes (directeur général, sections du personnel, de la comptabilité et des questions juridiques, etc.).
- Le "VSL" (Laboratoire van Swinden), 50 personnes environ, est chargé de la réalisation des étalons nationaux, des étalonnages à différents niveaux de précision et de la gestion de la NKO (Organisation néerlandaise d'étalonnage).

- Le “IJKwezen”, 200 personnes, est le service de métrologie légale chargé de toutes les activités résultant de la législation en la matière.
- Le centre “TAC”, 10 personnes environ, constitue un centre de conseils et d'éducation en métrologie.

Le quartier général du NMI, ainsi que le VSL et le Bureau TAC, se trouvent à Delft. Le “IJKwezen” est situé à Dordrecht. Enfin, le NMI dispose de bureaux régionaux à Zwolle, Schiedam, Amsterdam et 's-Hertogenbosch.



Fig. 2 — Bâtiments du NMI à Delft

The NETHERLANDS MEASUREMENT INSTITUTE (NMI)

by Gerard J. FABER

Deputy Director-General of NMI (*)

SUMMARY — Having received the assent of the Parliament of the Kingdom of the Netherlands, the “privatisation” of the Dutch metrological service took effect from the 1st May, 1989. The new organisation, called NMI (Netherlands Measurement Institute) is fully independent, but all its shares are held by the State. NMI is responsible for everything to do with legal metrology, and for the maintenance of international relations in the European Communities, OIML and BIPM.

Some historical facts

For some years now the Dutch government has pursued a policy of privatisation, with the following objectives :

- a) a smaller but more highly qualified civil service,
- b) an improvement in the state's finances,
- c) a strengthening of the private sector.

In December 1984 the government decided in principle to privatise the “Ijkwezen”, that is the metrological service. The service was instructed to study, within a time scale of six months, the conditions under which privatisation would be appropriate. The competent department, that is the Ministry of Economic Affairs, and the directorate of the service itself reached the conclusion that privatisation was practicable, indeed desirable, if the following conditions were satisfied :

- the service must be privatised in its entirety, that is that all its activities and skills should remain under one roof,
- a distinction should not be made between “deciders” and “doers”,
- the privatised service must retain all its authority to apply the law in the field of metrology.

After long parliamentary debates ending in December 1988 it was finally decided that the date for privatisation should be the 1st of May, 1989. The service is now called the Nederlands Meetinstituut (NMI).

Significance of the term “privatisation”

In fact the term “privatisation” is rather inappropriately applied to NMI. Generally “privatisation” means the transfer of public duties to a private organisation, but for NMI the expression “made independent” would be more appropriate, for it makes clear that the original Institute continues in all its activities and with the same responsibilities, but is no longer under state management.

The character of the new Institute

During visits to the metrological services of various countries, I have noticed that there is often a misconception of the nature of the new Institute. Does it have the necessary authority ? Is it still to be regarded as a partner on the international circuit ? To remove all misunderstanding, here are the main facts about NMI :

(*) Mr. G.J. Faber has been appointed Director General of NMI with effect from 1st January, 1990, thus succeeding Mr. J.M. Wolf.

1. NMI continues to be the sole official organ of legal metrology in the Netherlands.
2. NMI is officially responsible for pattern approval and for the initial and subsequent verification of measuring instruments, and for metrological surveillance.
3. NMI is fully mandated by the government to represent the country internationally (EC, OIML, BIPM).
4. NMI constitutes the responsible office in the Netherlands for the national standards of measurement.
5. NMI is responsible for the management and surveillance of NKO (Dutch calibration service).
6. NMI initiates metrological legislation.
7. All the shares of NMI are held by the state, and the latter may not sell these shares without parliamentary assent.

The future

NMI is a relatively strong and well funded organisation with a staff of about 300 people.

A moderate rate of growth is foreseen, mainly due to an increasing number of calibrations. Legally based activities (pattern approvals, verifications) will remain at the same level.

NMI as an institute enjoys a good reputation in Europe. Its management is very confident of its future, and "privatisation" enables it to react rapidly and efficiently to the metrological needs emerging in society in the 1990's.

Organisational chart of NMI

The organisational chart of NMI comprises four units (see Figure 1) :

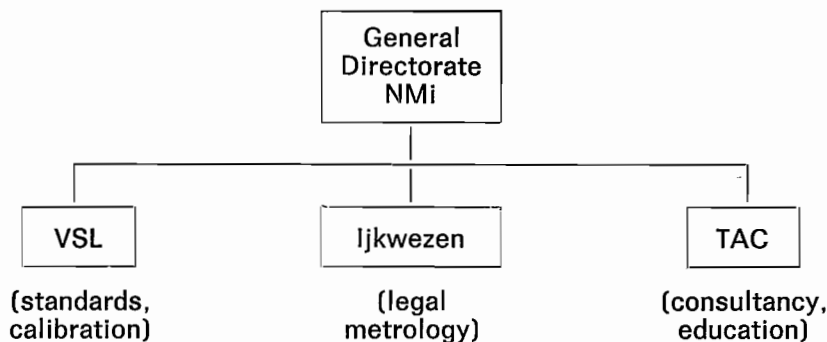

Fig. 1 — NMI's Organisational Chart

- The General Directorate of NMI employs about 40 people (Director-General, personnel department, accounts, legal department, etc.).
- VSL (Van Swinden Laboratory), about 50 people, is responsible for the realisation of the national standards, calibration at various levels of accuracy, and the management of NKO (Dutch calibration service).
- "Ijkwezen", 200 people, is the service of legal metrology, responsible for all activities arising from relevant legislation.
- The "TAC" centre, about 10 people, is a centre for consultancy and education in metrology.

The headquarters of NMI, as well as VSL and the TAC office, are at Delft ; "Ijkwezen" is at Dordrecht. Ijkwezen has regional offices at Zwolle, Schiedam, Amsterdam and 's-Hertogenbosch.

TCHECOSLOVAQUIE

COMPARISON of GEOMETRIC CALIBRATION METHODS for STORAGE MEASURING TANKS *

by Yvan CHREN

Czechoslovak Metrological Institute
Banská Bystrica

SUMMARY — The article analyses some sources of error in the calibration by mechanical means of cylindrical vertical tanks using the method of direct measuring of inner radii (A-method) and the method of determining the circumference in a reference plane by strapping combined with measurement of the radial offsets from vertical lines by jacket copying (B-method).

RESUME — Cet article donne une analyse des sources d'erreurs dans les jaugeages par des moyens mécaniques des réservoirs cylindriques verticaux utilisant soit la méthode de mesure directe des diamètres intérieurs (méthode A) soit la méthode de ceinturage dans un plan de référence combinée avec la mesure des écarts radiaux par rapport à la verticale par copiage de l'enveloppe du réservoir (méthode B).

Description of the Compared Methods

Up to the present day classical methods of measurement of the tank dimensions by the use of measuring tapes occupy a well-founded position among the geometric methods of calibration of cylindrical vertical tanks. They are simple, reliable and undemanding as for instrumentation or personnel qualification. They can be employed where explosiveness of the environment does not allow to use electrical measuring apparatus.

To such methods belong the method of measuring the inner radii of tanks (hereafter the A-method), and the method of measuring the circumference of a tank using the technique of jacket copying according to the CMEA Member Countries Standard (the B-method). A comparison of the precision of both methods was carried out in connection with the introduction of the CMEA Member Countries Standard in Czechoslovakia.

Method A

This method is used for calibration of tanks with a floating roof. The height of the active part of the tank is divided into a sufficient number of equivalent sections in which the inner R_i radii are measured in several and evenly distributed planes

* This article was written for the OIML seminar on Calibration of liquid volume measuring installations, Arles, 11-15 May 1987. A French version can be obtained from BIML.

passing the tank axis. The area of the tank section (S_A) in the specified part is determined from the mean radius

$$R_A = \frac{1}{n} \sum R_i \quad (1)$$

according to the following equation :

$$S_A = \pi \cdot R_A^2 \quad (2)$$

The R_i radii are determined by measuring the distance of the inner wall of the tank from the central point on the floating roof by means of a measuring tape the error of which does not exceed ± 0.01 %.

Method B

In the case of this method the outer or inner circumferences of the tank are measured (using a tape, or a special rule) from which the inner radius and sectional area are determined.

The actual shape of the tank walls above the basic plane is determined by jacket copying (inner or outer) by means of a carriage with a plumb-line. The deviations of the wall shape referred to the basic plane measured by copying in vertical lines of points evenly distributed on the tank circumference are used to determine the inner radii and sections at different heights.

The tank sectional area in the basic plane is as follows :

$$S_B = \frac{U^2}{4\pi} \quad (3)$$

where U is the inner circumference determined as a mean of three measurements which coincide within ± 0.01 %. The error of the copying measurements carried out on the tanks having radii higher than 10 m does not exceed ± 0.01 %.

The total evaluated accuracy of both calibration methods is ± 0.1 %, which allows to verify the tanks used in commercial contracts with an admissible error of ± 0.5 % and more.

Analysis of Errors in the Methods Compared

1. Effect of the tank non-circular section

If S is an area section determined by the A or B-methods, and S_o is the actual area, then the error of the method caused by a non-circular section can be written as follows :

$$e_1 = \frac{S - S_o}{S_o} \quad (4)$$

To assess this error it is assumed that the tank section has a shape of a) an ellipse, b) a regular polygon.

a) The actual sectional area in this case is as follows :

$$S_o = \pi \cdot a \cdot a^2 \quad (5)$$

where a is the length of the main half-axis, and α is the ratio of the side half-axis to the main one. If the R_i radii in Eq. 1 are expressed by means of the polar ellipse equation and the section $S = S_A$ determined by the method A (Eq. 2) is substituted into Eq. 4, the A-method error has the form as follows :

$$e_{1,A} = \alpha \cdot C_1^2(\alpha, n) - 1 \quad (6)$$

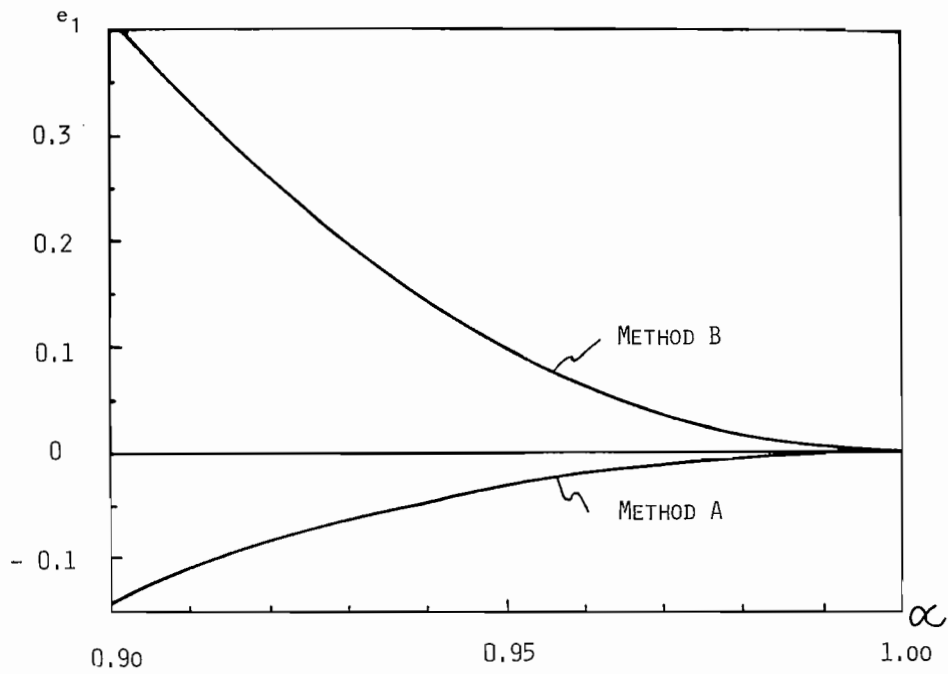

Fig. 1 — Influence of the ellipticity of the tank section
 e_1 = error due to the ellipticity in percent
 α = ratio between the two perpendicular axes of the ellipse

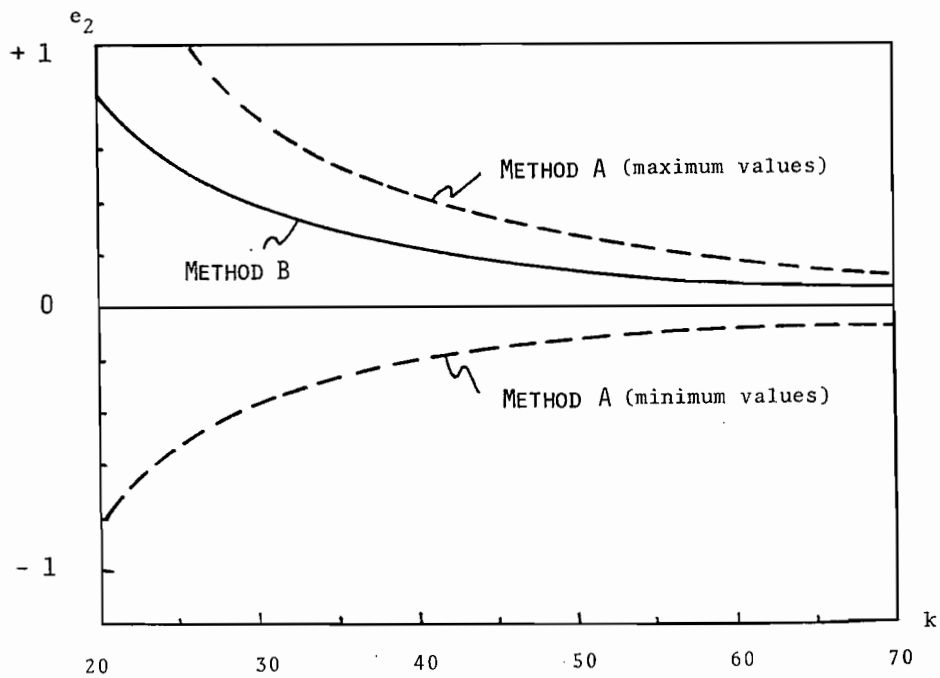

Fig. 2 — Influence of tank angularity
 e_2 = error due to angularity in percent
 k = number of sides of a regular polygon

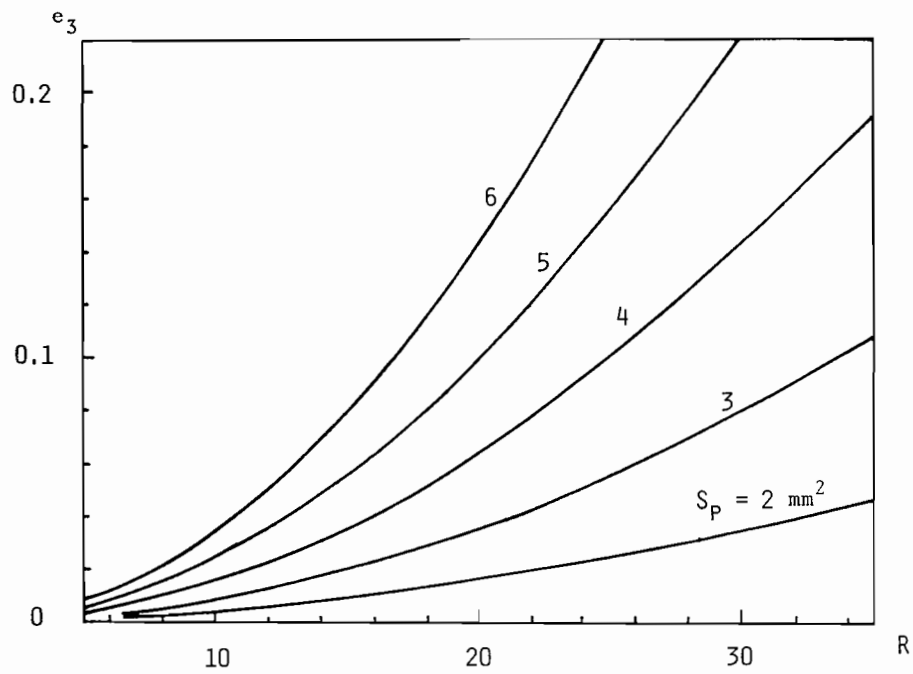

Fig. 3 — Influence of measuring tape flexion
 e_3 = error due to flexion of the tape in percent
 R = radius of the tank in metres

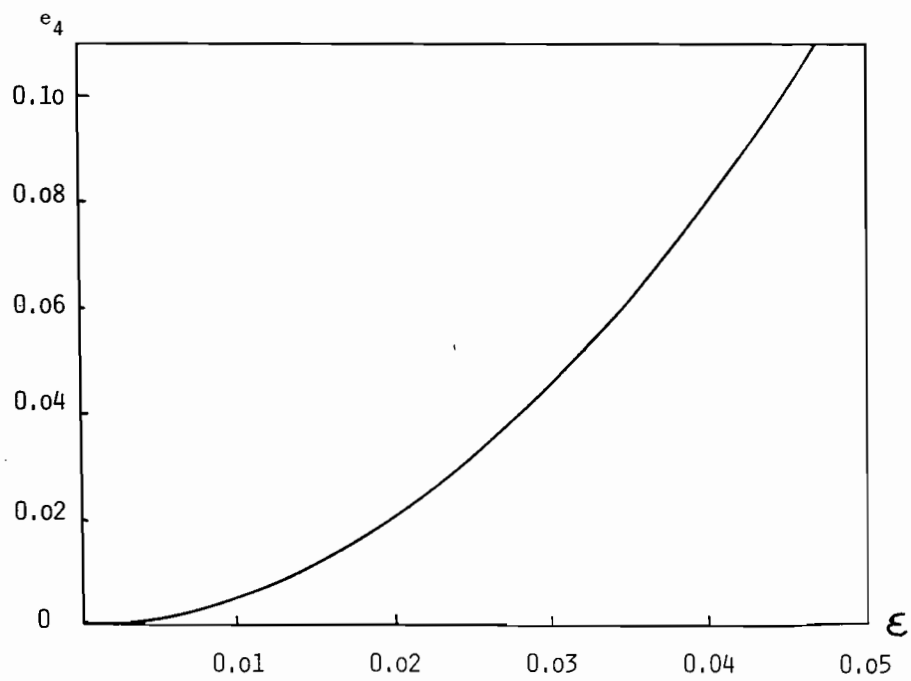

Fig. 4 — Influence of the excentricity of the position of the central tip
 e_4 = error due to the excentricity in percent
 ϵ = ratio of the tip excentricity to the tank radius

where

$$C_1(\alpha, n) = \frac{1}{n} \sum_{i=1}^n \left[1 - (1 - \alpha^2) \cdot \cos^2 \left(\frac{2 \cdot \pi \cdot i}{n} \right) \right]^{1/2} \quad (7)$$

In the case of ellipses with a small eccentricity ($\alpha = 0.8$) and a higher number of measurements of the tank radii ($n \geq 12$) which is always satisfied in the case of the A-method, the function $C_1(\alpha, n)$ and thus also the error of the method are independent on n .

In the case of the B-method the tank circumference equals the ellipse length, and thus, if using Eqs. 3, 4 and 5 for the error of the method the following relationship is valid :

$$e_{1, B} = \frac{1 - C_2(\alpha)^2}{\alpha} - 1 \quad (8)$$

where

$$C_2(\alpha) = \sum_{i=1}^{\infty} \frac{(1 - \alpha^2)^i}{2i - 1} \prod_{j=1}^i \left(\frac{2j - 1}{2j} \right)^2 \quad (9)$$

The course of the errors of the A and B-methods due to the elliptical section of the tank for $\alpha \geq 0.9$ is illustrated in Fig. 1. It is evident from the figure that the effect studied has an opposite effect on the methods (decreases the error of the A-method and increases the error of the B-method), and that the A-method is less sensitive to this effect.

b) In this case, the sectional area S_o is an area of a regular polygon with k sides and d lengths :

$$S_o = \frac{k \cdot d^2}{4} \operatorname{ctg} \frac{\pi}{k} \quad (10)$$

In the case of the A-method the error magnitude depends on the number n and distribution of the planes of measuring the R_i radii. The error acquires extreme values if the radii are measured in the apexes or centres of the polygon sides. Thus, the following equation is valid :

$$\frac{\pi}{k} \cdot \operatorname{ctg} \frac{\pi}{k} - 1 \leq e_{2, A} \leq \frac{2\pi}{k} \cdot \sin^{-1} \frac{2\pi}{k} - 1 \quad (11)$$

For enumeration of the B-method error it is sufficient to substitute the polygon circumference $U = k \cdot d$ into Eq. 3. Using Eqs. 4 and 10 we get

$$e_{2, B} = \frac{k}{\pi} \cdot \operatorname{tg} \frac{\pi}{k} - 1 \quad (12)$$

The error of the B-method and the limits of the A-method error caused by the tank angularity are shown in Fig. 2.

2. Effect of tape flexion (only with the A-method)

When measuring the tank radius with a measuring tape this is bent under its own weight and thus, the length of the arc is measured instead of the direct distance of the wall from the tank centre. As the bend of the tape is very small in comparison with the distance measured, it can be determined from the relationship for a para-

bolic catenary with suspensions at the same height. The equation of the line for deflection is used for the bend length calculation. With this method it is possible to find out that the relative error of the e_R radius measurement caused by the tape deflection is as follows :

$$e_R = \frac{1}{6} \left(\frac{\rho \cdot g \cdot S_p \cdot R}{2 T} \right)^2 \quad (13)$$

where ρ , S_p are the material density and the tape sectional area and T is the stretching force (equal to the prescribed force for which the tape was tested), g is the acceleration due to gravity.

The error of the A-method is the error of sectional area determination having thus a doubled value :

$$e_{3,A} = 2 \cdot e_R \quad (14)$$

Its dependence on the tank radius R is shown in Fig. 3 where the following values were used : $\rho = 7850 \text{ kg} \cdot \text{m}^{-3}$, $T = 50 \text{ N}$ and $g = 9.81 \text{ m} \cdot \text{s}^{-2}$.

3. Effect of the central tip eccentricity (for the A-method only)

If the central tip position does not coincide with the geometrical centre of the tank (circle), the error of determination of the sectional area using the A-method is as follows :

$$e_{4,A} = (1 + \varepsilon^2) \cdot C_3(\varepsilon, n) - 1 \quad (15)$$

where

$$C_3(\varepsilon, n) = \frac{1}{n} \sum_{i=1}^n \sqrt{1 + \frac{2\varepsilon}{1 + \varepsilon^2} \cdot \cos(2\pi i/n)} \quad (16)$$

and ε is the relative eccentricity of the central tip (ratio of the tip eccentricity to the tank radius), and n is the number of measurements of the R_i radii.

The relationship for $C_3(\varepsilon, n)$ has been derived using the law of cosines for expressing R_i in Eq. 1. The function of this error for eccentricities up to 0.05 and $n \geq 5$ is shown in Fig. 4.

Experimental Comparison of the Methods

A comparison of the methods was carried out in three tanks with identical total volumes (tanks No. 1 to 3), and in two tanks with a double volume (tanks No. 4 and 5). All the tanks were calibrated using both methods in such a way as in practice, i.e. by adjustment of the central tip, but without corrections for the deflections of the tape in the case of the A-method. The effect of angularity of the tanks was not considered as their jackets were made by coiling the sheets into a helix.

For the comparison of these methods calibration tables were prepared expressing the dependence of the volume on the height of filling, and relative differences e_V of the volumes V_A , V_B determined by the A and B-methods were calculated :

$$e_V = \frac{V_A - V_B}{V_B}$$

The values obtained at different relative h/h_{\max} levels are shown in Table 1.

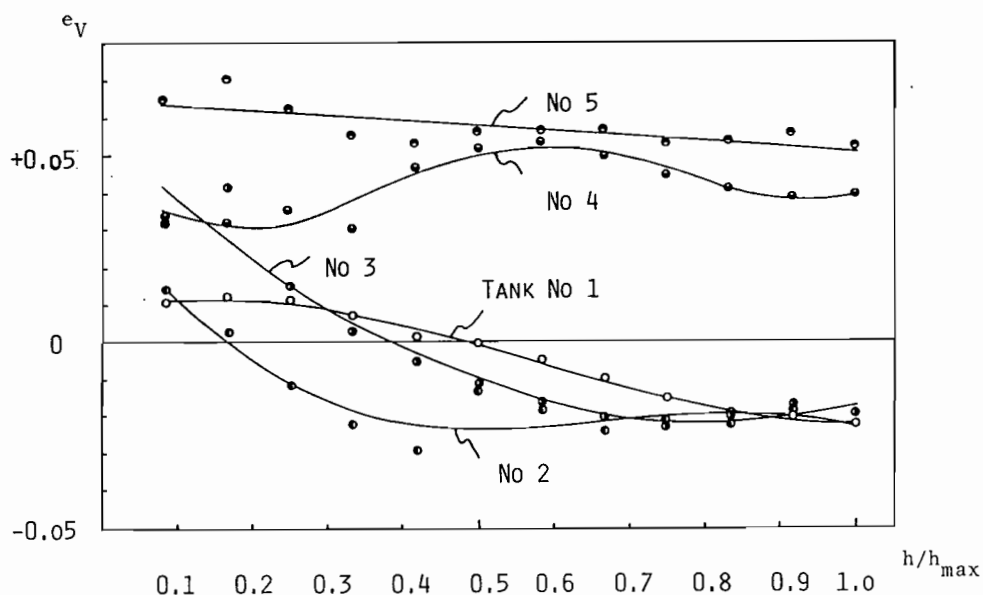

Fig. 5 — Results of the comparison of methods A and B
 e_v = relative difference in volume in percent
 h/h_{max} = relative height of the liquid level

Table 1 : Relative differences in the tank volumes at calibration by the A and B-methods

Tank No.	1	2	3	4	5
h/h_{max}	Relative differences in volumes in 0.01 %				
0.08	1.10	1.46	3.14	3.41	6.53
0.17	1.22	0.29	4.19	3.23	7.09
0.25	1.17	— 1.17	1.50	3.57	6.24
0.33	0.70	— 2.16	0.29	3.08	5.54
0.42	0.17	— 2.92	— 0.51	4.70	5.32
0.50	— 0.04	— 1.38	— 1.19	5.23	5.62
0.58	— 0.46	— 1.83	— 1.59	5.44	5.65
0.66	— 0.99	— 2.40	— 2.06	4.99	5.68
0.75	— 1.52	— 2.16	— 2.25	4.51	5.32
0.83	— 1.90	— 2.30	— 1.94	4.09	5.35
0.92	— 2.03	— 1.91	— 1.74	3.88	5.54
1.00	— 2.22	— 2.24	— 1.96	3.95	5.22

The dependence of $e_v = f(h/h_{max})$ was approximated by the method of the least squares. The resulting curves are shown in Fig. 5.

Discussion

The relative differences in the volumes found by the comparison methods ranged from -0.03 to $+0.07$ %. In Fig. 5 the difference in the position of the curves for small and large tanks is clearly evident (tanks No. 4, 5 versus tanks No. 1 to 3). The difference can be explained by the error caused by bending of the tape when the

A-method is used. In the specified case (section and density of the material used for the tape, radii of the tanks) this error is higher by 0.049 % when calibrating the tanks under the numbers 4 and 5 in comparison with the case of the measurements with the tanks No. 1 to 3. To eliminate the effect of the tank size on the results of the comparison it seems to be quite wise to correct the differences of the e_v in the case of the large tanks (No. 4, 5) with the use of the above mentioned value.

For a proper interpretation of the results of the comparison one should take into consideration the fact that while in the case of the A-method the results of the measurement are independent, in the case of the B-method the section methods at different heights depend on the results of the measurement (circumference) in the basic plane. Thus, also the results of the comparison of both methods depend on the difference in e found in the basic plane (first line in Table 1).

The mean difference in \bar{e}_v in the basic plane and other tank height sections (except for the basic plane) and corresponding standard deviations s are as follows :

	Values in 0.01 %	
	\bar{e}_v	s
Basic planes	1.17	1.67
Remaining planes	— 0.58	1.51

Neither the above values of \bar{e}_v nor their differences can be considered statistically significant, i.e. they do not differ from zero.

By calculating the confidence interval for 99 % probability it can be found that the accuracy of the calibration methods compared coincides to ± 0.04 %.

With respect to the intrinsic errors of the determination of the section by A and B-methods (± 0.2 %) and possible errors caused by eventual elliptic sections and non-accurate adjustment of the central tip (Figs. 1 and 4) we consider these results to be very satisfactory.



IN MEMORIAM

Jerzy JASNORZEWSKI

Nous avons appris avec quelque retard le décès survenu le 14 mai de Monsieur Jerzy JASNORZEWSKI à l'âge de 83 ans.

Monsieur Jerzy JASNORZEWSKI a été adjoint au Directeur du BIML pendant 10 ans de 1959 à 1969 ; il avait auparavant pris une part active aux travaux préparatoires de la création de notre Organisation et à l'élaboration de la Convention Internationale de Métrologie Légale.

Dans son pays, la Pologne, il avait, après la deuxième guerre mondiale, beaucoup contribué à la reconstruction des bâtiments et au rétablissement du Service métrologique en collaborant avec Monsieur Z. RAUSZER, Président de l'Office Central des Mesures. Il fut pendant un certain temps chef de la section de mesures de longueurs et angles de cet institut et entretenait des contacts étroits de travail avec l'Institut de Géodésie et Cartographie.

Etant spécialisé en astronomie et métrologie géodésique, il donnait également des cours à la Faculté de Géodésie et Cartographie de l'Ecole polytechnique de Varsovie.

Bien qu'étant en retraite il prit part à plusieurs expéditions scientifiques dans le grand nord et notamment au Spitzberg.

Il était décoré de la Croix de Chevalier de l'Ordre de Renaissance de la Pologne, de la Croix d'Or du Mérite et de la Médaille d'Or pour services rendus en géodésie et cartographie. Dans toutes ses activités très variées, il restait surtout un excellent métrologiste.

*
**

We have been informed with some delay about the death on 14 May of Mr Jerzy JASNORZEWSKI at the age of 83.

Mr JASNORZEWSKI was assistant Director of BIML during ten years from 1959 to 1969 ; he had previously taken an active part in the preparations for the creation of our Organization and in the drafting of its International Convention.

In his own country, Poland, he had after the second world war much contributed to the reconstruction of the buildings and re-establishment of the metrology Service as collaborator to Mr Z. RAUSZER, President of the Central Bureau of Metrology. He was for some time chief of the section for measurements of length and angle and maintained close contacts with the Institute of Geodesy and Cartography.

Being a specialist in astronomy and geodesic metrology, he delivered also lectures at the Faculty of Geodesy and Cartography at the Polytechnic School at Warsaw.

When retired he took part in several scientific explorations in the great north and in particular at Spitzbergen.

He was decorated with the Cross of the Knights of the Polish Order of Renaissance, the Gold Cross of Merit and Gold Medal for rendered services in the field of geodesy and cartography. In all his very diversified activities he was mainly an excellent metrologist.

INFORMATIONS

MEMBRES DU COMITE

BELGIQUE — Mme HENRION, notre très actif membre du CIML pendant une quinzaine d'années, a depuis quelques temps pris sa retraite et le nouveau représentant de son pays est M. VOORHOF, Inspecteur Général du Service de la Métrologie.

CAMEROUN — Le nouveau membre du Comité désigné par le Gouvernement est M. E. NDOUGOU, Sous-directeur des Poids et Mesures de la Direction des Prix, Poids et Mesures, Ministère du Développement Industriel et Commercial.

ESPAGNE — Nous avons appris le décès de Monsieur Manuel CADARSO MONTALVO et nous exprimons nos plus sincères condoléances à ses proches et à ses collègues du Centro Espanol de Metrologia, les nouveaux laboratoires créés grâce à ses efforts.

POLOGNE — On nous a informés que M. T. PODGORSKI a pris sa retraite et que le nom d'un nouveau Membre du CIML nous sera communiqué par le Gouvernement.

MEMBRES CORRESPONDANTS

Le SENEGAL a été admis comme nouveau membre correspondant de l'OIML.

ORAN/ARSO

L'Organisation Régionale Africaine de Normalisation a l'intention d'étendre ses activités dans le domaine de la métrologie et dans ce but organise un séminaire et une réunion d'experts, du 10 au 16 octobre à Nairobi dont le thème est de passer en revue les systèmes de métrologie des pays membres de l'ORAN et de trouver des procédés pour améliorer les moyens métrologiques notamment par la création d'un réseau régional d'essais, de métrologie et d'instrumentation (ARSO-TMICNET).

CENTRE DE METROLOGIE COMMONWEALTH-INDE

Le Conseil Scientifique du Commonwealth (CSC) en collaboration avec le Bureau australien de développement international (AIDAB) et l'UNESCO a depuis 1977 dirigé et soutenu financièrement un programme de coopération en métrologie connu sous le titre Asia/Pacific Metrology Programme (APMP).

Douze ans après, APMP est devenu un maillon important entre, d'une part un certain nombre d'organisations et d'institutions internationales ou régionales et les différents laboratoires de métrologie, d'autre part.

L'approche du CSC pour les programmes scientifiques qui ont eu du succès, a été de trouver dans chaque cas une institution pour domicilier ou rattacher un programme. A la 15e réunion biennale du CSC, le Conseil a unanimement accepté la proposition de créer un centre de métrologie Commonwealth-Inde (CIMET) au National Physical Laboratory à la Nouvelle-Delhi qui constitue ainsi une liaison naturelle au programme APMP.

Ce centre nommé CIMET a été officiellement inauguré le 23 février 1989.

Parmi d'autres tâches, le CIMET fournira des moyens de formation pour groupes ou individuels dans des domaines choisis de la métrologie. Ces cours sont ouverts aux participants de tous les pays en développement du Commonwealth qui obtiennent un soutien financier du programme de bourse et formation du secrétariat du Commonwealth (FTP). Des ressortissants des autres pays peuvent également participer en obtenant le soutien financier d'autres agences internationales spécialement concernées par la métrologie.

CONGRES INTERNATIONAL DE METROLOGIE EN ESPAGNE

La 4e Conférence internationale de mesures industrielles et d'essais aura lieu à Saragosse du 15 au 17 novembre 1989 en liaison avec l'exposition internationale METROMATICA qui concerne l'instrumentation et l'automatisation industrielles. Pour inscription et autres informations, s'adresser à E.T.S. Ingenieros Industriales — Congreso de Metrologia, Maria de Luna, 3, 50015 SARAGOSSE

Tél. (976)517020 — Télex : 58498 ETSIZ — Fax (976)512932

LITTERATURE

REP. FED. D'ALLEMAGNE

La deuxième édition du manuel de pesage édité sous la direction de notre membre du CIML M. Manfred KOCHSIEK vient de paraître. Ce livre a été mis à jour et très largement complété (avec près de 200 pages) par rapport à la première édition annoncée dans notre Bulletin No. 100 en 1985. On peut dire sans le moindre doute possible que ce livre représente actuellement la publication la plus complète disponible dans le domaine des instruments de pesage comportant à la fois des descriptions de la théorie et des produits industriels pratiquement réalisés dans ce domaine :

M. Kochsiek (Hrsg)
Handbuch des Wägens
2, Auflage, 849 pages, 680 figures, 1989
Editeur : Friedr. Vieweg & Sohn, Braunschweig

MEXIQUE

L'Asociacion Mexicana de Metrologia fut créée le 12 juillet 1988. Elle a pour but de diffuser les connaissances en métrologie, de promouvoir et de publier les recherches en métrologie réalisées au Mexique et de contribuer à la création d'une communauté nationale professionnelle s'occupant des recherches et développements en métrologie.

Le premier numéro de la revue de l'association dont le titre est "de la Metrologia" a été publié en tant que No. 0 en septembre 1988 et le No. 1 a suivi en janvier 1989. Ces premiers numéros contiennent des articles d'un grand intérêt pratique et relatifs entre autres sujets à l'étalonnage en force des machines d'essais, transferts de courant alternatif/courant continu, intercomparaisons d'étalons de pression, construction d'un bain thermostaté, métrologie de plans de référence (marbres), étalonnage de thermomètres en verre, etc.

ROYAUME-UNI

Les mesures de débits massiques ont pris de l'importance ces dernières années et des travaux ont été entrepris aussi bien par OIML que par ISO dans ce domaine. Une bonne documentation de base sur ce sujet peut être trouvée dans les comptes rendus d'une conférence internationale qui s'est tenue dernièrement à Londres : Proceedings of the International Conference on direct and indirect Mass Flow Measurement, London, 21-22 February 1989, publiés par IBC Technical Services Ltd, Canada Road, Byfleet, Surrey KT14 7JL.

URSS

Un grand nombre de livres relatifs à la métrologie sont publiés en russe. Beaucoup de ces ouvrages ont le caractère de livres d'enseignement ou ont pour but de mettre au courant les ingénieurs et les métrologistes des derniers développements dans les domaines concernés.

Le BIML a reçu en cadeau trois livres récemment publiés dont un est écrit par notre Membre du CIML, Mr A.I. Mekhannikov en coopération avec B.I. Malichev. Ce livre traite en particulier des systèmes de mesure modernes comportant des micro-processeurs, des capteurs de conception récente, etc. Son titre est :

“Gibkie izmeritelnie, sistemi b metrologi” Moscow (1988).

Les deux autres sont des ouvrages collectifs, édités sous la direction de B.K. Korobov et concernent d'une part des mesures radioélectriques, incluant temps et fréquences et d'autre part des mesures physico-techniques telles que basse température, dureté, pression dynamique, acoustique, conductivité, etc. Les titres de ces livres sont donnés ci-après dans la version anglaise des informations.

ONUDI

Nous signalons la parution d'une nouvelle revue “Afrique Industrie” (version française) publiée par l'ONUDI et dont le but est d'attirer l'attention des Africains et de la communauté internationale en général sur les efforts entrepris pour accélérer l'industrialisation dans différents pays d'Afrique. Le premier numéro, juin 1989, contient entre autres un article sur la maîtrise de la qualité des produits industriels en Afrique par le Directeur de la division des institutions et services industriels, Monsieur H.A. Hamdy et son collaborateur en métrologie, normalisation et contrôle qualité, Monsieur B. Goubet. Cet article mentionne le succès des programmes du type intégré assistés par l'ONUDI notamment au Sénégal et à l'île Maurice et suggère la création d'un laboratoire primaire régional de métrologie.

INFORMATION

COMMITTEE MEMBERS

BELGIUM — Mrs. HENRION, who was a very active member of CIML for about fifteen years has retired since some time already and the new representative of her country is Mr VOORHOF, Inspecteur Général, Service de la Métrologie.

CAMEROON — The new member designated by the Government is Mr E. NDOUGOU, Sous-directeur des Poids et Mesures, Ministère du Développement Industriel et Commercial.

SPAIN — We have been informed about the death this summer of Mr Manuel CADARSO MONTALVO and express our most sincere condolences to his relatives and to his colleagues at Centro Espanol de Metrologia, the recently constructed Laboratories which were created thanks to his efforts.

POLAND — It has been announced that Mr T. PODGORSKI has retired and that a new CIML member will be designated by the Government.

CORRESPONDING MEMBERS

SENEGAL has been admitted as new corresponding member of OIML.

ARSO

The African Regional Organization for Standardization intends to increase its metrology activities and organizes therefore a Workshop and expert group meeting on metrology in Nairobi 10-16 October during which the metrology systems of its Member States will be reviewed and a regional strategy discussed for upgrading metrology facilities including the establishment of a regional network of testing, metrology and instrumentation centres in Africa (ARSO-TMICNET).

COMMONWEALTH-INDIA METROLOGY CENTRE (CIMET)

The Commonwealth Science Council (CSC) in collaboration with Australian International Development Bureau (AIDAB) and UNESCO has, since 1977, run a programme on metrology known as the Asia/Pacific Metrology Programme (APMP).

Twelve years later, the APMP has become an important link between a number of international and regional organizations/agencies on the one hand, and various national measurement laboratories on the other.

The CSC approach to successful scientific programmes has been to find a home to domicile a programme or to be associated with the programme. Last November, at the 15th Biennial Meeting of the Commonwealth Science Council, the Council welcomed and unanimously endorsed the proposal for a Commonwealth India Metrology Centre (CIMET) to be established at India's National Physical Laboratory, New Delhi, as a natural adjunct to the Asia/Pacific/Metrology Programme.

The Commonwealth-India Metrology Centre (CIMET) was formally inaugurated at the National Physical Laboratory, New Delhi, on 23 February 1989.

Among others, CIMET will provide facilities for both group training in metrology and individual training in selected fields of metrology to participants from all developing Commonwealth Countries, with financial support from Commonwealth Secretariat's Fellowship and Training Programme (FTP). Participants from non-Commonwealth countries will also be able to attend the training programmes with financial support from other international agencies with specialised interest in metrology and allied areas.

INTERNATIONAL METROLOGY CONFERENCE IN SPAIN

The 4th International Conference on Industrial Measurement and Testing is organized in Zaragoza 15-17 November 1989 in connection with the international exhibition METROMATICA which covers instrumentation and industrial automation. For registration and further information contact : E.T.S. Ingenieros Industriales — Congreso de Metrologia, Maria de Luna, 3, 50015 ZARAGOZA

Tel. : (976)517020 — Telex : 58498 ETSIZ — Fax (976)512932

LITERATURE

FED. REP. OF GERMANY

A second edition of the handbook on weighing edited under the direction of our CIML member Manfred KOCHSIEK has just been published. This book has been updated and greatly enlarged (by almost 200 pages) with respect to the first edition which was announced in the OIML Bulletin No. 100 in 1985.

One may without any uncertainty say that it presently constitutes the most complete publication available on weighing instrumentation including descriptions of both theory and practical industrially realized products within its field :

Manfred Kochsiek (Hrsg)

Handbuch des Wägens

2. Auflage, 849 pages, 680 figures, 1989

Publisher : Friedr. Vieweg & Sohn, Braunschweig.

MEXICO

The Mexican metrology society Asociacion Mexicana de Metrologia was founded on 12 July 1988 with the scope of distributing the knowledge of metrology, publish research in metrology realized in Mexico and contribute to the creation of a national professional community engaged in metrology research and development.

The first number of the review of the society called "de la Metrologia" was issued as No. 0 in September 1988 and No. 1 followed in January 1989. These first issues include papers of great practical interest covering among other subjects the calibration of force testing machines, AC/DC transfer, intercomparisons of pressure standards, construction of a thermostated bath, surface plate metrology, calibration of liquid-in-glass thermometers, etc.

UNITED KINGDOM

Mass flow measurements have gained great interest in recent years and work has started by both OIML and ISO on Recommendations and Standards in this field. A good background documentation on the subject can be found in the Proceedings of the International Conference on direct and indirect Mass Flow Measurement, London, 21-22 February 1989, which may be purchased from IBC Technical Services Ltd, Canada Road, Byfleet, Surrey KT14 7JL.

USSR

A number of books related to metrology are frequently published in Russian language many of which are educational or have the purpose of informing engineers and metrologists about recent developments in the fields concerned.

The BIML has received as a gift three of recently published books with such aims, one of which is written by our CIML member Dr. A.I. Mekhannikov in co-operation with B.I. Malichev and treating measuring systems, use of microprocessors in metrology, sensors, etc. :

“Gibkie izmeritelnie, sistemi b metrologi” Moscow (1988).

The two others are collective works and concern on the one hand the field of radioelectricity including time and frequency and on the other hand physico-technical measurements (low temperature, hardness, dynamic, pressure, acoustics, conductivity etc.) :

Korobov (Ed.) — “Aktualnie problemi metrologi b radioelektronike”, Moscow (1985)

and

Korobov (Ed.) — “Sobremennie metrologicheskie problemi fisiko-technicheskikh ismerenij” Moscow (1988).

The publisher of all three books is Isdatelsvo Standartov, Moscow.

UNIDO

A new journal called “Industry Africa” (English version) is now published by UNIDO. Its aim is to draw the attention of the African peoples and the international community to the efforts made to promote and accelerate industrialization in Africa. The first issue No. 1, June 1989, contains among others an article with the title “Ensuring industrial product quality in Africa” written by the Director of the UNIDO Industrial Institutions and Services Division, Mr H.A. Hamdy and his collaborator in metrology, standardization and quality control, Mr B. Goubet. This article mentions the success of the so-called integrated programmes assisted by UNIDO in particular in Senegal and Mauritius and suggests the creation of a regional primary laboratory for metrology.

REUNIONS OIML

Groupes de travail		Dates	Lieux
SP 17	Mesure des pollutions	} 1-5 oct. 1989	WABERN SUISSE
SP 17-Sr 1	Mesure des pollutions de l'air		
SP 27	Principes généraux de l'utilisation des matériaux de référence en métrologie légale	} 23-27 oct. 1989	SVERDLOVSK URSS
SP 27-Sr 4	Principes de détermination des valeurs certifiées des matériaux de référence		
SP 27-Sr 5	Principes d'utilisation des matériaux de référence		
SP 5D-Sr 7	Méthodes et dispositifs de vérification des instruments de mesure de liquides	} 6-10 nov. 1989	TSUKUBA JAPON
SP 5D-Sr 9	Compteurs vortex		
SP 7-Sr 5	Instruments de pesage à fonctionnement automatique	7-11 mai 1990	TEDDINGTON ROYAUME-UNI
SP 12-Sr 7	Thermomètres médicaux	8-11 mai 1990	R.F. d'ALLEMAGNE
SP 7-Sr 4	Instruments de pesage à fonctionnement non automatique	21-23 mai 1990 (provisoire)	BRAUNSCHWEIG R.F. d'ALLEMAGNE
SP 8-Sr 5	Poids utilisés dans le commerce et l'industrie	} mai 1990 (provisoire)	
SP 8-Sr 6	Poids de précision		
Séminaire technique de l'OIML : Instruments de pesage électroniques		15-18 mai 1990	BRAUNSCHWEIG R.F. d'ALLEMAGNE

Note : Cette liste a été établie le 30 septembre 1989 et peut ne plus être à jour.
This list was established 30th September 1989 and may no longer be up to date.

PUBLICATIONS

- Vocabulaire de métrologie légale
Vocabulary of legal metrology
- Vocabulaire international des termes fondamentaux et généraux de métrologie
International vocabulary of basic and general terms in metrology

RECOMMANDATIONS INTERNATIONALES

INTERNATIONAL RECOMMENDATIONS

R N°

- 1 — Poids cylindriques de 1 g à 10 kg (de la classe de précision moyenne)
Cylindrical weights from 1 g to 10 kg (medium accuracy class)
- 2 — Poids parallélépipédiques de 5 à 50 kg (de la classe de précision moyenne)
Rectangular bar weights from 5 to 50 kg (medium accuracy class)
- 3 — Voir R 76
See R 76
- 4 — Fioles jaugées (à un trait) en verre
Volumetric flasks (one mark) in glass
- 5 — Compteurs de liquides autres que l'eau à chambres mesureuses
Meters for liquids other than water with measuring chambers
- 6 — Dispositions générales pour les compteurs de volume de gaz
General provisions for gas volume meters
- 7 — Thermomètres médicaux (à mercure, en verre, avec dispositif à maximum)
Clinical thermometers (mercury-in-glass, with maximum device)
- 9 — Vérification et étalonnage des blocs de référence de dureté Brinell
Verification and calibration of Brinell hardness standardized blocks
- 10 — Vérification et étalonnage des blocs de référence de dureté Vickers
Verification and calibration of Vickers hardness standardized blocks
- 11 — Vérification et étalonnage des blocs de référence de dureté Rockwell B
Verification and calibration of Rockwell B hardness standardized blocks
- 12 — Vérification et étalonnage des blocs de référence de dureté Rockwell C
Verification and calibration of Rockwell C hardness standardized blocks
- 14 — Saccharimètres polarimétriques
Polarimetric saccharimeters

- 15 — Instruments de mesure de la masse à l'hectolitre des céréales
Instruments for measuring the hectolitre mass of cereals
- 16 — Manomètres des instruments de mesure de la tension artérielle (sphygmo-
manomètres)
Manometers for instruments for measuring blood pressure (sphygmomanometers)
- 17 — Manomètres, vacuomètres, manovacuumètres indicateurs
Indicating pressure gauges, vacuum gauges and pressure-vacuum gauges
- 18 — Pyromètres optiques à filament disparaissant
Visual disappearing filament pyrometers
- 19 — Manomètres, vacuomètres, manovacuumètres enregistreurs
Recording pressure gauges, vacuum gauges, and pressure-vacuum gauges
- 20 — Poids des classes de précision E_1 E_2 F_1 F_2 M_1 de 50 kg à 1 mg
Weights of accuracy classes E_1 E_2 F_1 F_2 M_1 from 50 kg to 1 mg
- 21 — Taximètres
Taximeters
- 22 — Tables alcoométriques internationales
International alcoholometric tables
- 23 — Manomètres pour pneumatiques de véhicules automobiles
Tyre pressure gauges for motor vehicles
- 24 — Mètre étalon rigide pour agents de vérification
Standard one metre bar for verification officers
- 25 — Poids étalons pour agents de vérification
Standard weights for verification officers
- 26 — Seringues médicales
Medical syringes
- 27 — Compteurs de volume de liquides (autres que l'eau). Dispositifs complémentaires
Volume meters for liquids (other than water). Ancillary equipment
- 28 — Voir R 76
See R 76
- 29 — Mesures de capacité de service
Capacity serving measures
- 30 — Mesures de longueur à bouts plans (calibres à bouts plans ou cales-étalons)
End standards of length (gauge blocks)
- 31 — Compteurs de volume de gaz à parois déformables
Diaphragm gas meters
- 32 — Compteurs de volume de gaz à pistons rotatifs et compteurs de volume de
gaz à turbine
Rotary piston gas meters and turbine gas meters

- 33 — Valeur conventionnelle du résultat des pesées dans l'air
Conventional value of the result of weighing in air
- 34 — Classes de précision des instruments de mesurage
Accuracy classes of measuring instruments
- 35 — Mesures matérialisées de longueur pour usages généraux
Material measures of length for general use
- 36 — Vérification des pénétrateurs des machines d'essai de dureté
Verification of indenters for hardness testing machines
- 37 — Vérification des machines d'essai de dureté (système Brinell)
Verification of hardness testing machines (Brinell system)
- 38 — Vérification des machines d'essai de dureté (système Vickers)
Verification of hardness testing machines (Vickers system)
- 39 — Vérification des machines d'essai de dureté (systèmes Rockwell B, F, T - C, A, N)
Verification of hardness testing machines (Rockwell systems B, F, T - C, A, N)
- 40 — Pipettes graduées étalons pour agents de vérification
Standard graduated pipettes for verification officers
- 41 — Burettes étalons pour agents de vérification
Standard burettes for verification officers
- 42 — Poinçons de métal pour agents de vérification
Metal stamps for verification officers
- 43 — Fioles étalons graduées en verre pour agents de vérification
Standard graduated glass flasks for verification officers
- 44 — Alcoomètres et aréomètres pour alcool et thermomètres utilisés en alcoométrie
Alcoholometers and alcohol hydrometers and thermometers for use in alcoholometry
- 45 — Tonneaux et futailles
Casks and barrels
- 46 — Compteurs d'énergie électrique active à branchement direct (de la classe 2)
Active electrical energy meters for direct connection (class 2)
- 47 — Poids étalons pour le contrôle des instruments de pesage de portée élevée
Standard weights for testing of high capacity weighing machines
- 48 — Lampes à ruban de tungstène pour l'étalonnage des pyromètres optiques
Tungsten ribbon lamps for calibration of optical pyrometers
- 49 — Compteurs d'eau (destinés au mesurage de l'eau froide)
Water meters (intended for the metering of cold water)
- 50 — Instruments de pesage totalisateurs continus à fonctionnement automatique
Continuous totalising automatic weighing machines
- 51 — Trieuses pondérales de contrôle et trieuses pondérales de classement
Checkweighing and weight grading machines
- 52 — Poids hexagonaux. Classe de précision ordinaire de 100 g à 50 kg
Hexagonal weights. Ordinary accuracy class, from 100 g to 50 kg
- 53 — Caractéristiques métrologiques des éléments récepteurs élastiques utilisés pour le mesurage de la pression. Méthodes de leur détermination
Metrological characteristics of elastic sensing elements used for measurement of pressure. Determination methods

- 54 — Echelle de pH des solutions aqueuses
pH scale for aqueous solutions
- 55 — Compteurs de vitesse, compteurs mécaniques de distances et chronotachygraphes des véhicules automobiles - Réglementation métrologique
Speedometers, mechanical odometers and chronotachographs for motor vehicles. Metrological regulations
- 56 — Solutions-étalons reproduisant la conductivité des électrolytes
Standard solutions reproducing the conductivity of electrolytes
- 57 — Ensembles de mesurage de liquides autres que l'eau équipés de compteurs de volumes. Dispositions générales
Measuring assemblies for liquids other than water fitted with volume meters. General provisions.
- 58 — Sonomètres
Sound level meters
- 59 — Humidimètres pour grains de céréales et graines oléagineuses
Moisture meters for cereal grains and oilseeds
- 60 — Réglementation métrologique des cellules de pesée
Metrological regulations for load cells
- 61 — Doseuses pondérales à fonctionnement automatique
Automatic gravimetric filling machines
- 62 — Caractéristiques de performance des extensomètres métalliques à résistance
Performance characteristics of metallic resistance strain gages
- 63 — Tables de mesure du pétrole
Petroleum measurement tables
- 64 — Exigences générales pour les machines d'essai des matériaux
General requirements for materials testing machines
- 65 — Exigences pour les machines d'essai des matériaux en traction et en compression
Requirements for machines for tension and compression testing of materials
- 66 — Instruments mesureurs de longueurs
Length measuring instruments
- 67 — Ensembles de mesurage de liquides autres que l'eau équipés de compteurs de volumes. Contrôles métrologiques
Measuring assemblies for liquids other than water fitted with volume meters. Metrological controls
- 68 — Méthode d'étalonnage des cellules de conductivité
Calibration method for conductivity cells
- 69 — Viscosimètres à capillaire, en verre, pour la mesure de la viscosité cinématique
Glass capillary viscometers for the measurement of kinematic viscosity.
- 70 — Détermination des erreurs de base et d'hystérésis des analyseurs de gaz
Determination of intrinsic and hysteresis errors of gas analysers
- 71 — Réservoirs de stockage fixes. Prescriptions générales
Fixed storage tanks. General requirements

- 72 — Compteurs d'eau destinés au mesurage de l'eau chaude
Hot water meters
- 73 — Prescriptions pour les gaz purs CO, CO₂, CH₄, H₂, O₂, N₂ et Ar destinés à la préparation des mélanges de gaz de référence
Requirements concerning pure gases CO, CO₂, CH₄, H₂, O₂, N₂ and Ar intended for the preparation of reference gas mixtures
- 74 — Instruments de pesage électroniques
Electronic weighing instruments
- 75 — Compteurs d'énergie thermique
Heat meters
- 76 — Instruments de pesage à fonctionnement non automatique
Non-automatic weighing instruments

Partie 1 : Exigences métrologiques et techniques - Essais
Part 1 : Metrological and technical requirements - Tests

Partie 2 : Rapport d'essai de modèle
Part 2 : Pattern evaluation report
- 77 — Ensembles de mesurage de liquides autres que l'eau équipés de compteurs de volumes. Dispositions particulières relatives à certains ensembles
Measuring assemblies for liquids other than water fitted with volume meters. Provisions specific to particular assemblies
- 78 — Pipettes Westergren pour la mesure de la vitesse de sédimentation des'hématies
Westergren tubes for measurement of erythrocyte sedimentation rate
- 79 — Etiquetage des préemballages
Information on package labels
- 80 — Camions et wagons-citernes
Road and rail tankers
- 81 — Dispositifs et systèmes de mesure de liquides cryogéniques (comprend tables de masse volumique pour argon, hélium, hydrogène, azote et oxygène liquides)
Measuring devices and measuring systems for cryogenic liquids (including tables of density for liquid argon, helium, hydrogen, nitrogen and oxygen)
- 87 — Contenu net des préemballages
Net content in packages

DOCUMENTS INTERNATIONAUX

INTERNATIONAL DOCUMENTS

D N°

- 1 — Loi de métrologie
Law on metrology
- 2 — Unités de mesure légales
Legal units of measurement
- 3 — Qualification légale des instruments de mesurage
Legal qualification of measuring instruments
- 4 — Conditions d'installation et de stockage des compteurs d'eau froide
Installation and storage conditions for cold water meters
- 5 — Principes pour l'établissement des schémas de hiérarchie des instruments de mesure
Principles for the establishment of hierarchy schemes for measuring instruments
- 6 — Documentation pour les étalons et les dispositifs d'étalonnage
Documentation for measurement standards and calibration devices
- 7 — Evaluation des étalons de débitmétrie et des dispositifs utilisés pour l'essai des compteurs d'eau
The evaluation of flow standards and facilities used for testing water meters
- 8 — Principes concernant le choix, la reconnaissance officielle, l'utilisation et la conservation des étalons
Principles concerning choice, official recognition, use and conservation of measurement standards
- 9 — Principes de la surveillance métrologique
Principles of metrological supervision
- 10 — Conseils pour la détermination des intervalles de réétalonnage des équipements de mesure utilisés dans les laboratoires d'essais
Guidelines for the determination of recalibration intervals of measuring equipment used in testing laboratories
- 11 — Exigences générales pour les instruments de mesure électroniques
General requirements for electronic measuring instruments
- 12 — Domaines d'utilisation des instruments de mesure assujettis à la vérification
Fields of use of measuring instruments subject to verification
- 13 — Conseils pour les arrangements bi- ou multilatéraux de reconnaissance des : résultats d'essais - approbations de modèles - vérifications
Guidelines for bi- or multilateral arrangements on the recognition of : test results - pattern approvals - verifications
- 14 — Formation du personnel en métrologie légale - Qualification - Programmes d'étude
Training of legal metrology personnel - Qualification - Training programmes
- 15 — Principes du choix des caractéristiques pour l'examen des instruments de mesure usuels
Principles of selection of characteristics for the examination of measuring instruments

- 16 — Principes d'assurance du contrôle métrologique
Principles of assurance of metrological control
- 17 — Schéma de hiérarchie des instruments de mesure de la viscosité des liquides
Hierarchy scheme for instruments measuring the viscosity of liquids
- 18 — Principes généraux d'utilisation des matériaux de référence certifiés dans les mesurages
General principles of the use of certified reference materials in measurements
- 19 — Essai de modèle et approbation de modèle
Pattern evaluation and pattern approval
- 20 — Vérifications primitive et ultérieure des instruments et processus de mesure
Initial and subsequent verification of measuring instruments and processes

Note — Ces publications peuvent être acquises au / *These publications may be purchased from*
Bureau International de Métrologie Légale, 11, rue Turgot, 75009 PARIS.



ORGANISATION INTERNATIONALE DE MÉTROLOGIE LÉGALE

ETATS MEMBRES

ALGERIE	INDONESIE
REP. FEDERALE D'ALLEMAGNE	IRLANDE
REP. DEMOCRATIQUE ALLEMANDE	ISRAEL
AUSTRALIE	ITALIE
AUTRICHE	JAPON
BELGIQUE	KENYA
BRESIL	LIBAN
BULGARIE	MAROC
CAMEROUN	MONACO
CANADA	NORVEGE
REP. POP. DE CHINE	PAKISTAN
CHYPRE	PAYS-BAS
REP. DE COREE	POLOGNE
REP. POP. DEM. DE COREE	PORTUGAL
CUBA	ROUMANIE
DANEMARK	ROYAUME-UNI DE GRANDE-BRETAGNE ET D'IRLANDE DU NORD
EGYPTE	SRI LANKA
ESPAGNE	SUEDE
ETATS-UNIS D'AMERIQUE	SUISSE
ETHIOPIE	TANZANIE
FINLANDE	TCHECOSLOVAQUIE
FRANCE	TUNISIE
GRECE	U.R.S.S.
HONGRIE	YOUgoslavie
INDE	

MEMBRES CORRESPONDANTS

Albanie - Bahrein - Bangladesh - Barbade - Botswana - Burkina Faso - Colombie - Costa Rica - Equateur
Fidji - Ghana - Hong Kong - Irak - Islande - Jordanie - Koweït - Luxembourg - Malaisie - Mali - Maurice
Mexique - Népal - Nouvelle-Zélande - Oman - Panama - Pérou - Philippines - Sénégal - Seychelles - Syrie
Trinité et Tobago - Turquie - Venezuela

MEMBRES
du
COMITE INTERNATIONAL de METROLOGIE LEGALE

ALGERIE

Membre à désigner par son Gouvernement
Correspondance adressée à
Office National de Métrologie Légale
1, rue Kaddour Rahim Hussein Dey
ALGER

REPUBLIQUE FEDERALE D'ALLEMAGNE

Mr M. KOCHSIEK
Directeur
Physikalisch-Technische Bundesanstalt,
Bundesallee 100 - Postfach 3345
3300 BRAUNSCHWEIG.
TP 49-531-592 80 10 TC 49-531-592 76 14
TX 9-52 822 PTB
TG Bundesphysik Braunschweig

REPUBLIQUE DEMOCRATIQUE ALLEMANDE

Mr K. HASCHE
Leiter der Fachabteilung "Mechanik/Metrologie
in der Fertigungstechnik"
Amt für Standardisierung, Messwesen,
und Warenprüfung,
Fürstenwalder Damm 388
1162 BERLIN.
TP 37-2-65 260
TX 112630 asmw

AUSTRALIE

Mr J. BIRCH
Executive Director
National Standards Commission,
P.O. Box 282
NORTH RYDE, N.S.W. 2113.
TP 61-2-888 39 22 TC 61-2-888 30 33
TX AA 23144
TG NATSTANCOM Sydney

AUTRICHE

Mr R. LEWISCH
Director of the Metrology Service
Vice-President of Bundesamt für Eich- und
Vermessungswesen
Postfach 20
Arltgasse 35
A-1163 WIEN.
TP 43-222-92 16 27 TC 43-222-73 79 95
TX 115 468 bevwn

BELGIQUE

Mr H. VOORHOF
Inspecteur Général
Service de la Métrologie
24-26, rue J.A. De Mot
B-1040 BRUXELLES
TP 32-2-233 61 11 TC 32-2-230 83 00
TX 20 627 COM HAN

BRESIL

Mr MASAO ITO
Président, INMETRO
Praça Mauah N° 7, 13 Andar
20081 RIO DE JANEIRO
TP 55-21-233 1586 et 233 1184
TX 2134599 IMNQ BR

BULGARIE

Mr V. TZAREVSKI
Vice-Président
Comité de la Qualité auprès du Conseil des
Ministres de la R.P. de Bulgarie
21, rue du 6 Septembre
1000 SOFIA
TP 359-2-8591
TX 22 570 DKS BG
TG techprogress

CAMEROUN

Mr E. NDOUGOU
Sous-Directeur des Poids et Mesures
Direction des Prix, Poids et Mesures
Ministère du Développement Industriel
et Commercial
B.P. 501
YAOUNDE
TP 237-22 35 69
TX 82-68 à Yaoundé

CANADA

Mr R.G. KNAPP
Director, Legal Metrology Branch
Consumer and Corporate Affairs
207, rue Queen
OTTAWA, Ontario K1A 0C9
TP 1-613-952 0655
TX 053 3694

REPUBLIQUE POPULAIRE DE CHINE

Mr BAI JINGZHONG
Deputy Director General
State Bureau of Technical Supervision
P.O. Box 2112
BEIJING
TP 86-1-44 43 04
TX 210209 SBTS CN
TG 1918 Beijing

CHYPRE

Mr M. EROTOKRITOS
Director General
Ministry of Commerce and Industry
NICOSIA.
TP 357-21-40 34 41
TX 2283 MIN COMIND
TG mincommind Nicosia

REPUBLIQUE DE COREE

Mr SON BOCK-GILL
 Director of Metrology Division
 Bureau of Standards
 Industrial Advancement Administration
 2, Chung-and-dong,
 KWACH'ON, KYONGGI-DO 171-11
 TP 82-2-590 89 90
 TG KORIAA.

REPUBLIQUE POP. DEM. DE COREE

Mr DJEUNG KI TCHEUL
 Directeur de l'Institut Central de Métrologie
 auprès du Comité National de la Science
 et de la Technologie
 Arrondissement de Sadong
 PYONGYANG
 TG standard

CUBA

Membre à désigner par son Gouvernement
 Correspondance adressée à :
 Mr Acosta Alemany
 Comite Estatal de Normalizacion
 Egido 610 e/Gloria and Apodaca
 HABANA Vieja
 TP 7-67901 et 619587
 TX 512236 CENDH
 TG CEN HAVANA

DANEMARK

Mr Ove E. PETERSEN
 Senior Executive Engineer
 Division of Metrology
 National Agency of Industry and Trade
 Tagensvej 135
 DK-2200 COPENHAGEN N
 TP 45-1-85 10 66 TC 45-1-81 70 68
 TX 15768 INDTRA DK

EGYPTE

Mr M. HILAL
 Président,
 Egyptian Organization for Standardization
 and Quality Control
 2 Latin America Street, Garden City
 CAIRO.
 TP 20-2-26 355
 TX 93 296 EOS
 TG TAWHID

ESPAGNE

Membre à désigner par son Gouvernement
 Correspondance adressée à :
 Centro Espanol de Metrologia
 c/ del alfar s/n
 28760 TRES CANTOS (Madrid)
 TP 34-1-803 33 03 TC 34-1-803 11 78
 TX 47254 CEME E

ETATS-UNIS D'AMERIQUE

Mr S.E. CHAPPELL
 Chief, Office of Standards Management
 Office of the Associate Director for Industry
 and Standards
 National Institute of Standards and Technology
 Bldg. 101, A625
 GAITHERSBURG, Maryland 20899
 TP 1-301-975 40 24 TC 1-301-975 21 28
 TX 197674 NBS UT

ETHIOPIE

Mr Yohannes AFEWORK
 Head of Technical Service
 Ethiopian Authority for Standardization
 P.O. Box 2310
 ADDIS ABABA.
 TP — 15 04 00 et 15 04 25
 TG ETHIOSTAN

FINLANDE

Madame U. LÄHTEENMÄKI
 Director of Metrology Department
 Technical Inspection Centre
 Box 204
 SF 00181 HELSINKI 18
 TP 358-0-61 671 TC 358-0-605 474
 TG TEKTARTOS HKI

FRANCE

Mr Ph. BERTRAN
 Sous-Directeur de la Métrologie
 S.A.R.S.C.I. Ministère de l'industrie et de l'amé-
 nagement du territoire
 30-32, rue Guersant
 75833 PARIS Cedex 17
 TP 33-1-45 72 85 85 TC 33-1-45 72 87 57
 TX 649 917 F

GRECE

Mr A. DESIS
 Technical Officer
 Directorate of Weights and Measures
 Ministry of Commerce
 Canning Sq.
 10181 ATHENS
 TP 30-1-36 14 168
 TX 21 67 35 DRAG GR et 21 52 82 YPEM GR

HONGRIE

Mr D. BELEDI
 Président, Országos Mérésügyi Hivatal,
 P.O. Box 19
 H-1531 BUDAPEST
 TP 36-1-1567 722
 TX 22-4856 OMH
 TG HUNG METER Budapest

INDE

Mr S. HAQUE
 Director, Weights & Measures
 Ministry of Food and Civil Supplies
 Weights and Measures Unit
 12-A, Jam Nagar House
 NEW DELHI 110 011
 TP 91-11-38 53 44
 TX 31 61962 COOP IN
 TG POORTISAHAKAR

INDONESIE

Mr G.M. PUTERA
Director of Metrology
Directorate General of Domestic Trade
Departemen Perdagangan
Jalan Pasteur 27
40171 BANDUNG.
TP 62-22-50 597 et 50 695
TX 28 176

IRLANDE

Mr J. LOWE
Assistant Secretary
Department of Industry and Commerce
Frederick Building, Setanta Centre,
South Frederick Street,
DUBLIN 2.
TP 353-1-61 44 44
TX 93478
TG TRADCOM Dublin

ISRAEL

Mr A. RONEN
Controller of Weights, Measures and Standards
Ministry of Industry and Trade
P.O.B. 299
JERUSALEM 91002
TP 972-2-27 241
TG MEMISCOM Jerusalem

ITALIE

Mr C. AMODEO
Capo dell'Ufficio Centrale Metrico,
Via Antonio Bosio, 15
00161 ROMA.
TP 39-6-348 78 34

JAPON

Mr S. HATTORI
Director General
National Research Laboratory of Metrology
1-4, Umezono 1-Chome, Tsukuba
IBARAKI 305.
TP 81-298-54 41 49 TC 81-298-54 41 35
TX 03652570 AIST
TG KEIRYOKEN TSUCHIURA

KENYA

Mr P.A. AYATA
Director of Weights and Measures
Weights and Measures Department
Ministry of Commerce
P.O. Box 41071
NAIROBI
TP 254-2-33 51 55 et 33 51 11
TG ASSIZERS, Nairobi

LIBAN

Membre à désigner par son Gouvernement
Correspondance à adresser à
Service des Poids et Mesures,
Ministère de l'Economie et du Commerce,
Rue Al-Sourati, imm. Assaf
RAS-BEYROUTH.
TP — 34 40 60

MAROC

Mr M. BENKIRANE
Chef de la Division de la Métrologie Légale
Direction de l'Industrie
5, rue Errich, Immeuble A, Quartier Hassan
RABAT.
TP 212-7-51 792
TX 31816 M

MONACO

Mr A. VEGLIA
Ingénieur au Centre Scientifique de Monaco
16, Boulevard de Suisse
MC 98000 MONTE CARLO
TP 33-93-30 33 71

NORVEGE

Mr K. BIRKELAND
Directeur Général
Service National de Métrologie
Postbox 6832 St. Olavs Plass
0130 OSLO 1
TP 47-2-20 02 26 TC 47-2-20 77 72

PAKISTAN

Mr M. ASAD HASAN
Director
Pakistan Standards Institution
39-Garden Road, Saddar
KARACHI-3.
TP 92-21-72 95 27
TG PEYASAI

PAYS-BAS

Mr G.J. FABER
Deputy Managing Director
Nederlands Meetinstituut nv
Postbus 654
2600 AR DELFT.
TP 31-15-69 15 00 TC 31-15-61 29 71
TX 38 373 IJKWZ NL

POLOGNE

Membre à désigner par son Gouvernement
Correspondance adressée à
Polski Komitet Normalizacji, Miar i Jakosci
ul. Elektoralna 2
00-139 WARSZAWA.
TP 48-22-20 54 34
TX 813 642 PKN
TG PEKANIM

PORTUGAL

Mr A. CRUZ
Directeur du Service de la Métrologie
Instituto Português da Qualidade
Rua Prof. Reinaldo Santos
Lote 1378
1500 LISBOA
TP 351-1-78 61 58 TC 351-1-78 19 80
TX 65744 METROQ P

ROUMANIE

Mr I. ISCRULESCU
Directeur, Institutul National de Metrologie,
Sos Vitan-Birzesti nr. 11
BUCAREST 4.
TP 40-0-83 23 20
TX 11 871

ROYAUME-UNI

Mr P.B. CLAPHAM
 Director,
 National Weights and Measures Laboratory
 Stanton Avenue
 TEDDINGTON, Middlesex TW 11 OJZ
 TP 44-1-943 72 72 TC 44-1-943 72 70
 TX 9312131043 (WM G)

SRI LANKA

Mr H.L.R.W. MADANAYAKE
 Deputy Commissioner of Internal Trade
 Measurement Standards and Services Division
 Department of Internal Trade
 101, Park Road
 COLOMBO 5.
 TP 94-1-83 261

SUEDE

Mr R. OHLON
 Ingénieur en Chef, Statens Provningsanstalt.
 P.O. BOX 857
 S-501 15 BORÅS.
 TP 46-33-16 50 00 TC 46-33-13 55 02
 TX 36252 TESTING S

SUISSE

Mr P. KOCH
 Vice-Directeur, Office Fédéral de Métrologie,
 Lindenweg 50
 3084 WABERN/BE.
 TP 41-31-59 61 11 TC 41-31-59 62 10
 TX 912860 TOPO CH
 TG OFMET

TANZANIE

Mr A.H.M. TUKAI
 Commissioner for Weights and Measures
 Weights and Measures Bureau
 P.O. Box 313
 DAR ES SALAAM
 TP — 64046
 TX 41689 INDIS

TCHECOSLOVAQUIE

Mr M. CIBAK
 Director
 Czechoslovak Institute of Metrology
 L. Novomeskeho 4
 842 55 BRATISLAVA
 TP 42-7-329 820 et 329 865
 TX 93486 CSMU
 TG METR BRATISLAVA

TUNISIE

Mr Ali BEN GAID
 Président Directeur Général
 Institut National de la Normalisation
 et de la Propriété Industrielle
 Boîte Postale 23
 1012 TUNIS BELVEDERE
 TP 216-1-785 922 TC 216-1-781 563
 TX 13 602 INORPI

U.R.S.S.

Mr A.I. MEKHANNIKOV
 Vice-Président
 Gosstandart
 Leninsky Prospect 9
 117049 MOSCOU.
 TP — 236 40 44
 TX 411 378 GOST
 TG Moskva-Standart

YOUGOSLAVIE

Mr M. MEZEK
 Directeur
 Bureau Fédéral des Mesures et Métaux Précieux
 Mike Alasa 14
 11000 BEOGRAD.
 TP 38-11-18 37 36
 TX 11 020 YUZMBG

TP = telephone TC = telecopie (telefax)

Les numéros sont en général indiqués pour le régime automatique international à l'exception des numéros qui sont précédés d'un trait.

The call numbers are generally indicated for international automatic dialling except where the local number is preceded by a dash.

TG = telegramme TX = telex

Pour tout télex ou télégramme, il est nécessaire d'indiquer le nom de la personne et sa qualité.
For all telex or telegrams it is necessary to indicate name of person and occupation.

PRESIDENCE

Président K. BIRKELAND, Norvège
1er Vice-Président ... A.I. MEKHANNIKOV, U.R.S.S.
2e Vice-Président ... S.E. CHAPPELL, U.S.A.

CONSEIL DE LA PRESIDENCE

K. BIRKELAND, Norvège, Président
A.I. MEKHANNIKOV, U.R.S.S., V/Président S.E. CHAPPELL, U.S.A., V/Président
M. KOCHSIEK, Rép. Féd. d'Allemagne Ph. BERTRAN, France
P.B. CLAPHAM, Royaume-Uni
Le Directeur du Bureau International de Métrologie Légale

BUREAU INTERNATIONAL DE METROLOGIE LEGALE

Directeur	B. ATHANÉ
Adjoint au Directeur	S.A. THULIN
Adjoint au Directeur	F. PETIK
Ingénieur Consultant	W.H. EMERSON
Administrateur	Ph. LECLERCO

MEMBRES D'HONNEUR

J. STULLA-GOTZ, Autriche — Président du Comité
H. MOSER, Rép. Féd. d'Allemagne — Membre du Conseil de la Présidence
V. ERMAKOV, U.R.S.S. — Vice-Président du Comité
A.J. van MALE, Pays-Bas — Président du Comité
A. PERLSTAIN, Suisse — Membre du Conseil de la Présidence
W. MUEHE, Rép. Féd. d'Allemagne — Vice-Président du Comité
H.W. LIERS, Rép. Dém. Allemande — Membre du Conseil de la Présidence

ADRESSES DES SERVICES DES MEMBRES CORRESPONDANTS

ALBANIE

Directeur
Drejtoria e Standardeve dhe e Mjeteve
Matëse (DSMA)
në Komisionin e Planit të Shtetit
TIRANA

BAHREIN

The Responsible of Metrology
Standards and Metrology Section
Ministry of Commerce and Agriculture
P.O. Box 5479
MANAMA

BANGLADESH

Director General
Bangladesh Standards and Testing Institution
116-A, Tejgaon Industrial Area
DHAKA 1208

BARBADE

Director
Barbados National Standards Institution
Culloden Road
St. Michael
BARBADOS W.I.

BOTSWANA

The Permanent Secretary
Division of Weights and Measures
Department of Commerce and Consumer Affairs
Private Bag 48
GABORONE

BURKINA FASO

Direction Générale des Prix
Ministère du Commerce
et de l'Approvisionnement du Peuple
B.P. 19
OUAGADOUGOU

COLOMBIE

Superintendencia de Industria y Comercio
Centro de Control de Calidad y Metrologia
Cra. 37 No 52-95, 4° piso
BOGOTA D.E.

COSTA RICA

Oficina Nacional de Normas y Unidades
de Medida
Ministerio de Economía y Comercio
Apartado 10 216
SAN JOSE

EQUATEUR

The Director General
Instituto Ecuatoriano de Normalizacion
Calle Baquerizo Moreno No 454
entre 6 de Diciembre y Almagro
Casilla No 3999
QUITO

FIDJI

The Chief Inspector of Weights and Measures
Ministry of Economic Development, Planning
and Tourism
Government Buildings
P.O. Box 2118
SUVA

GHANA

Ghana Standards Board
Kwame Nkrumah Conference Centre
(Tower Block - 2nd Bay, 3rd Floor)
P.O. Box M-245
ACCRA

HONG-KONG

Commissioner of Customs and Excise
(Attn. Trading Standards Investigation Bureau)
Room 1405, Wing on Centre
111 Connaught Road Central
HONG KONG

IRAK

Planning Board
Central Organization for Standardization
and Quality Control
P.O.B. 13032
Al Jadiria
BAGHDAD

ISLANDE

The Director
Weights and Measures in Iceland
Löggildingarstofan
Sidumula 13
P.O. Box 8114
128 REYKJAVIK

JORDANIE

Directorate of Standards
Ministry of Industry and Trade
P.O. Box 2019
AMMAN

KOWEIT

The Under Secretary
Ministry of Commerce and Industry
Department of Standards and Metrology
Post Box No 2944
KUWAIT

LUXEMBOURG

Le Préposé du Service de Métrologie
Administration des Contributions
Rue des Scillas
2529 HOWALD

MALAISIE

The Acting Director of Standards
Standards and Industrial Research Institute of
Malaysia
P.O. Box 35, Shah Alam
SELANGOR

MALI

Le Directeur Général des Affaires Economiques
(Service des Poids et Mesures)
B.P. 201
BAMAKO

MAURICE

The Permanent Secretary
Ministry of Trade and Shipping
(Division of Weights and Measures)
New Government Centre
PORT LOUIS

MEXIQUE

Dirección General de Normas
Secretaría de Comercio y Fomento Industrial
Sistema Nacional de Calibración
Ave. Puente de Tecamachalco no. 6 - Planta Baja
Lomas de Tecamachalco, Sección Fuentes
53950 NAUCALPAN DE JUAREZ

NEPAL

The Chief Inspector
Nepal Bureau of Standards and Metrology
P.B. 985
Sundhara
KATHMANDU

NOUVELLE-ZELANDE

The Chief Inspector of Weights and Measures
Ministry of Commerce
P.O. Box 1473
WELLINGTON

OMAN

The Director General
for Specifications and Measurements
Ministry of Commerce and Industry
P.O. Box 550
MUSCAT

PANAMA

Le Directeur
Comision Panamena de Normas Industriales
y Tecnicas
Ministerio de Comercio e Industrias
Apartado 9658
PANAMA 4

PEROU

The Director General
ITINTEC Instituto de Investigacion Tecnologica
Industrial y de Normas Tecnicas
Apartado 145
LIMA 100

PHILIPPINES

The Director
Product Standards Agency
Ministry of Trade and Industry
Trade & Industry Building
361 Sen. Gil J. Puyat Avenue
Makati, Metro Manila
PHILIPPINES 3117

SENEGAL

Monsieur le Directeur
Institut Sénégalais de Normalisation
Ministère du Plan et de la Coopération
DAKAR

SEYCHELLES

The Director
Seychelles Bureau of Standards
P.O. Box 199
INDEPENDENCE HOUSE

SYRIE

The General Director
The Syrian Arab Organization
for Standardization and Metrology
P.O. Box 11836
DAMASCUS

TRINITE ET TOBAGO

The Director
Trinidad and Tobago Bureau of Standards
P.O. Box 467
PORT OF SPAIN

TURQUIE

Le Directeur du Service des Poids et Mesures
Ticaret Bakanligi, Ölçüler ve Ayarlar
Müdür Vekili - Bakanliklar
ANKARA

VENEZUELA

Le Directeur
Dirección General de Tecnología
Servicio Nacional de Metrología
Ministerio de Fomento,
Av. Javier Ustariz, Edif. Parque Residencial
Urb. San Bernardino
CARACAS.

